

MODEL 9-500 & -500C
ILLUSTRATED PARTS BREAKDOWN MANUAL

FOR REFERENCE ONLY



MODEL 9-500
IPB Notice and Revision History

This document and the information contained herein is the property of Arc Machines, Inc. It is proprietary and submitted and received in confidence. It shall be used only for the purpose for which it is submitted and shall not be copied in whole or in part without the prior express written permission of Arc Machines, Inc. The information in this document has been carefully reviewed and is believed to be accurate. However, no responsibility is assumed for inaccuracies. Information and part numbers in this document are subject to change and Arc Machines, Inc. reserves the right to change required data without notice.

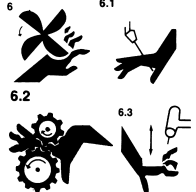

WARNING

The nature of the GTAW process creates some POTENTIAL HAZARDS. In accordance with international safety regulations the EXCLAMATION SYMBOL indicates that this equipment is considered HAZARDOUS. The LIGHTNING FLASH SYMBOL indicates that there are potential electrical hazards. The display of these symbols makes it the OPERATOR'S RESPONSIBILITY TO ENSURE THAT THEY HAVE BEEN MADE AWARE OF and shall observe the hazardous conditions.

	WARNING: AMI factory training is essential for all Maintenance Technicians who operate AMI equipment. Do not operate or service this equipment without proper AMI approved training.
	WARNING: Keep hands and fingers clear from moving parts such as fans, gears, rotors, Wire Feed, Weld Head Travel, i.e. Oscillation (OSC) and Arc Voltage Control (AVC) mechanisms Weld Head AVC and Oscillator Slide Assemblies develop high forces and it is possible, by their nature of operation, to harm any object or body part that may get into these areas. USE EXTREME CAUTION!
	Electrical Shock Hazard: Always disconnect weld heads when servicing internal components or opening housing covers for access.

Inc. All rights reserved.
Publication date: First Edition – June 5, 2007
Copyright 2007 by Arc Machines, Inc.

REV	ECO #	CHANGE DESCRIPTION	DATE	BY	APR
A	4590	Added new gear assembly. Cleaned up and put much of IPB into solidworks	26 Oct 2007	SO	LEC
REVISION TABLE CONTINUED ON NEXT PAGE.					

FOR REFERENCE ONLY

MODEL 9-500
IPB Notice and Revision History

REV	ECO #	CHANGE DESCRIPTION	DATE	BY	APR
B	4871	IPB 090124, ITEM 27 TO 13090654-01 WAS 13090638-01	23 May 2008	SO	BF
C	4942	On IPB 0901136, Item 24 P/N changed was MMW35 to MMGGD1W2C. On IPB 090124, Item 51 P/N changed from MMW35 to MMGGD1W2C	10 JUL 2008	SO	BF
D	5579	Replace 750074 with 750015 and add wiring diagram	18 Jan 2010	CB	DC
E	5676	Updated cover sheet; tab of cont; IPB 0901136 itm 15; IPB 090663 mdel #; IPB 090124 completely; added new Bom to 090124 and itm 1 13090780-02was -01, added item 20 420907241-01 backing plate; added IPB's 0090654 & 0090816 with Boms; deleted old Boms pages 20, 21 & 22	15 Sept 2010	GB	DC
F	5676A	Updated IPB 090124 to show optional parts, corrected wrong parts in 0905210 & 090654, corrected wrong ECO number entered on Revision History sheet for Rev E	28 Sept 2010	GB	DC
G	1190122	Updated IPB 090124; changed item 8 and 14. Updated IPB 0901136; changed items 9 and 12. Updated IPB 090658; added 13090658-02. Updated IPB 090654; added 13090654-02. Replaced IPB 090663 with new IPB 090668.	08 May 2012		DC
H	1190122B	Renamed IPB 090141, it was 090124. Changed Gear notes on IPB 0901136 and 090141.	13 Sept 2012	JS	DC
J	6508	Removed NOTE1 ON IPB 090141 AND 0901136; Removed 090668.	02/28/2013	LK	DC
K	6530	UPDATED IPB 0901136, 090141: CLARIFIED ITEM NO. AND CHANGED P/N OF ITEM31 (IPB 090141), P/N OF ITEM33 (IPB 0901136).	04/10/2013	LK	BL

FOR REFERENCE ONLY

TABLE OF CONTENTS

DATE EFFECTIVE: 21 MAR 2002

PRODUCT MODEL: 9-500
MANUAL NUMBER: 730046

IPB NUMBER	DESCRIPTION
750015	ELECTRODE DIMENSIONS
090141	M9-500 WELD HEAD ASSEMBLY BASIC (NON-WATER COOLED)
090654	DRIVE GEAR ASSEMBLY M9-500 (REPAIRABLE)
090816	CABLE ASSEMBLY M9-500
0901136	M9-500C WELD HEAD BASIC ASSEMBLY (WATER COOLED)
090658	M9-500C DRIVE GEAR (REPAIRABLE) ASSEMBLY
090836	M9-500C CABLE ASSEMBLY (WATER COOLED)
090511	CLAMP ASSEMBLY
0905217	MODIFIED CLAMP ASSY (MCA) WITH CLAMP INSERTS
0905216	UNIVERSAL CLAMP ASSY (UCA) WITH CLAMP INSERTS
0905245	TUBE CLAMP ASSY (TCA-2) WITH MINI CUBE AND MINI CUBE ADJUSTABL
0905246	MODIFIED CLAMP ASSY (MCA-2) WITH MINI CUBES AND CLAMP INSERTS
0905210	KIT CONVERSION QUICK RELEASE (FOR TCA-MCA-UCA)
0905138	KIT – CASSETTE CONVERSION ASSY/INSTALLATION
0905135-01	TUBE TO TUBE CASSETTE MODULE ASSEMBLY
0905135-02	TUBE TO FITTING CASSETTE MODULE ASSEMBLY
750026	MODEL 9-500 CASSETTE CONVERSION INSTRUCTIONS
175144-06	MODEL 9 WELD HEAD WIRING DIAGRAM

FOR REFERENCE ONLY

ELECTRODE DIMENSIONS

ROTOR DIAMETER	
MODEL NO.	ROTOR O.D.
9-250	0.802
9-500/4-500	1.388
9-675	1.715
9M-750	1.312
9-750	2.000
9-1500	3.187
9AF-1500	2.252
9E-1500	2.687
8-2000	3.450
9-2500	4.380
9AF-2500	3.156
9E-2500	4.280
* 9-3500	5.380
9E-3500	5.310
8-4000	5.310
* 9-4500	6.875
9ER-4500	5.776
8-6625	8.094
* 9-7500	10.440
9E-7500	9.375
* FOR HEADS USING OPTIONAL TUNGSTEN EXTENDER, SEE PAGE 2.	

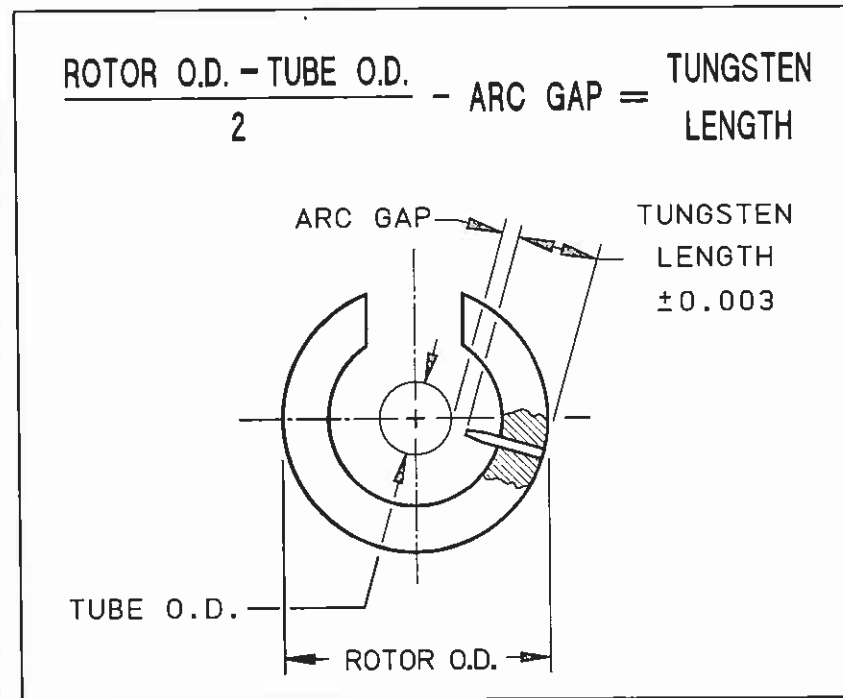

TUBE/PIPE WALL THICKNESS	RECOMMENDED ARC GAP	RECOMMENDED TIP DIA.
0.020/0.035	0.030	0.020
0.049/0.085	0.050	0.030
0.091/0.154	0.070	0.040

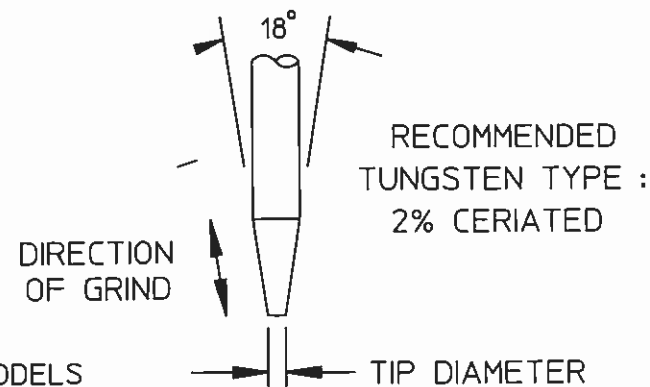

- NOTES:
1. RECOMMENDED ARC GAP FOR MODELS 4-500, 9-250 & 9-500 IS 0.045 MAXIMUM.
 2. IN INSTANCES WHERE OUT-OF-ROUNDNESS ON THIN-WALLED TUBING OCCURS (NORMALLY 2.500 O.D. OR LARGER), A 0.070 ARC GAP IS RECOMMENDED.
 3. DIMENSIONS ARE IN INCHES.

TUNGSTEN LENGTH CALCULATION FOR TUNGSTEN EXTENDERS

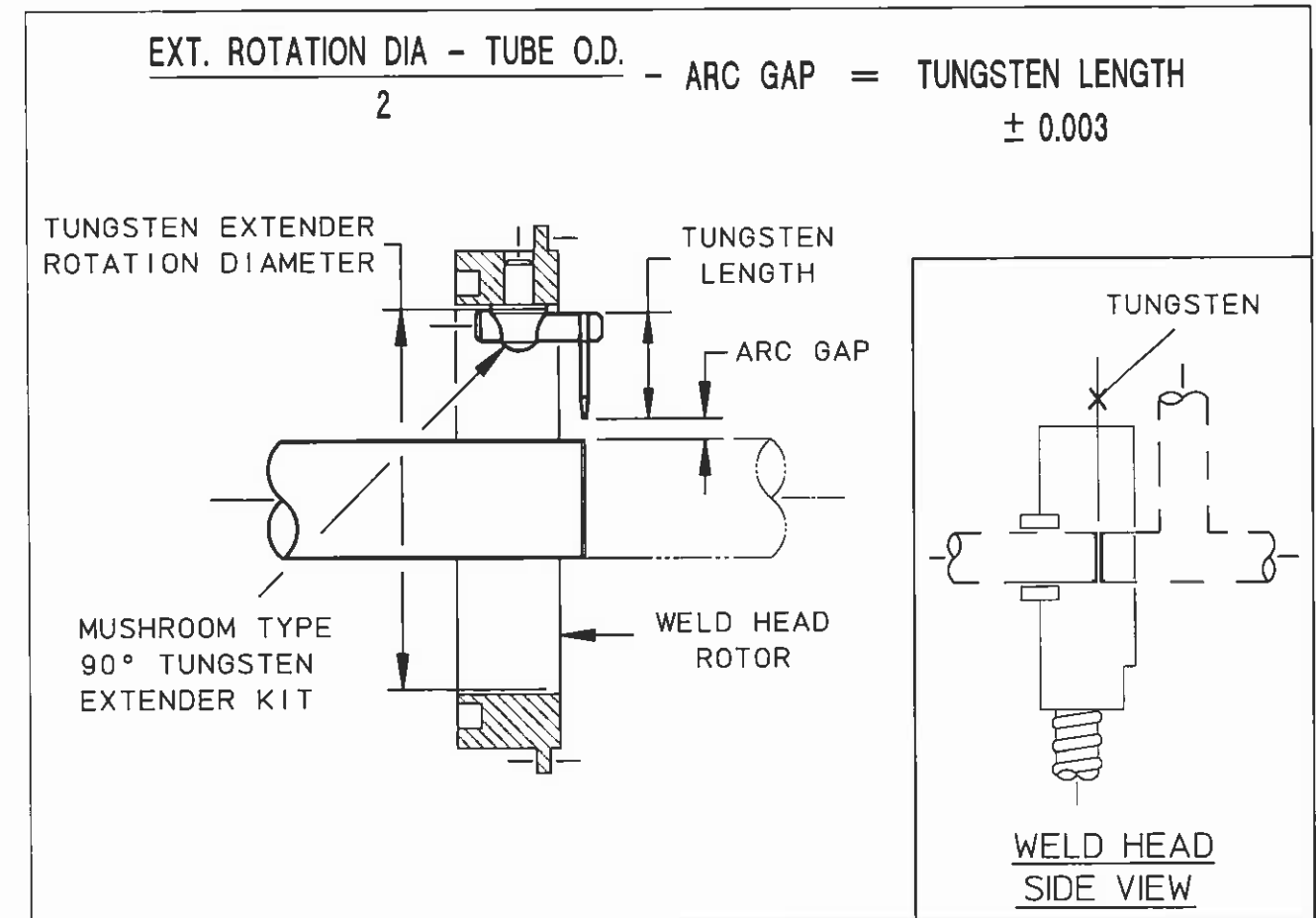

WELD HEAD MODEL NO.	KIT WITH 1/16 TUNGSTEN HOLDER PART NO.	KIT WITH 3/32 TUNGSTEN HOLDER PART NO.	TUNGSTEN EXTENDER ROTATION DIA.
9-1500	13090796-01	13090796-02	2.031
9-2500	13090796-05	13090796-06	3.156
9-3500	13090796-05	13090796-06	4.031
9-4500	13090796-03	13090796-04	4.920
9-7500	13090796-05	13090796-06	8.280

NOTES:

1. PART NUMBERS SHOWN ARE FOR REFERENCE ONLY AND ARE SUBJECT TO CHANGE.
2. CONTACT AMI SALES OR SERVICES FOR SPECIFIC PART NUMBER.

FOR REFERENCE ONLY

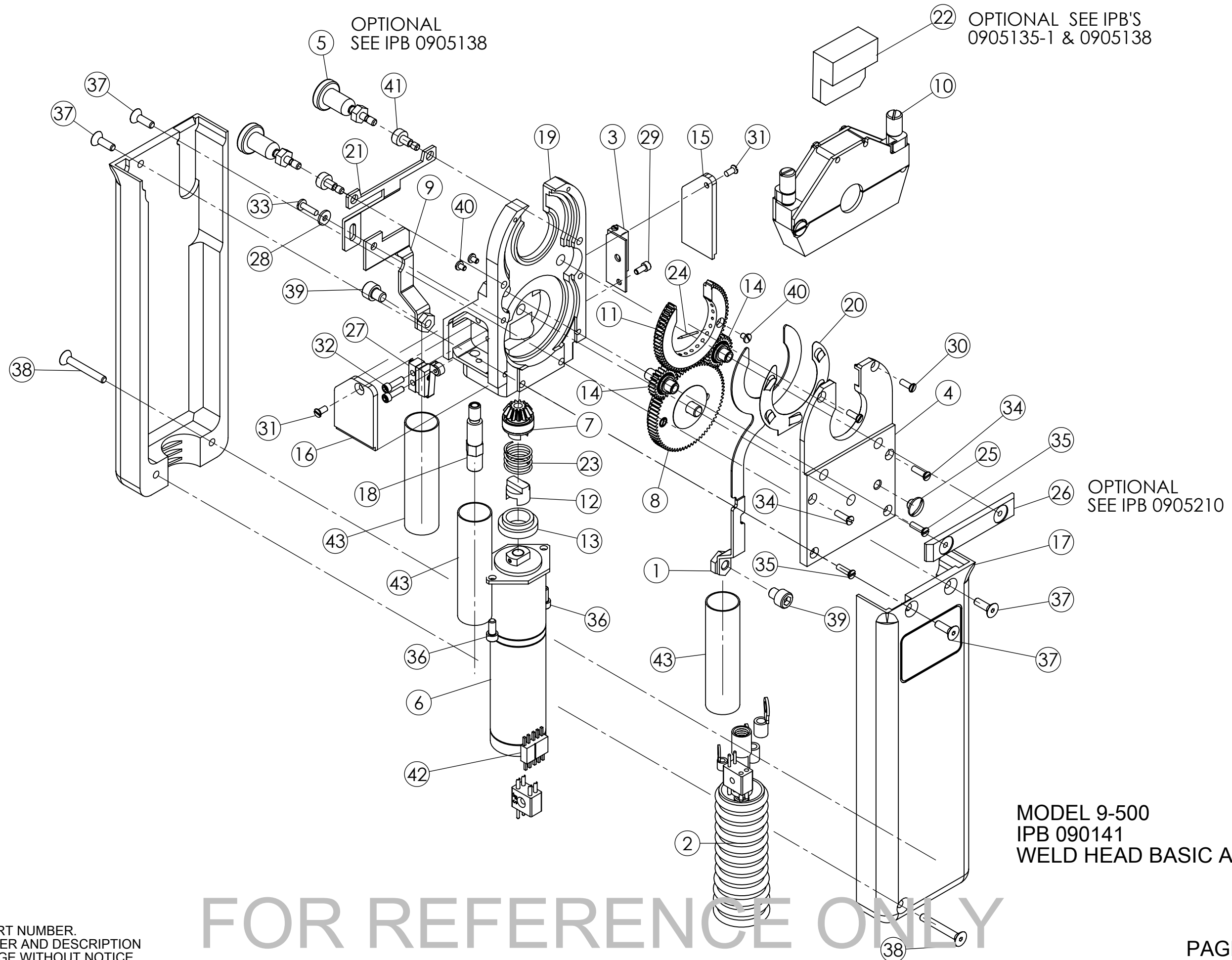

TO ORDER USE PART NUMBER.
PRICE, PART NUMBER AND DESCRIPTION
SUBJECT TO CHANGE WITHOUT NOTICE.

FOR REFERENCE ONLY

ITEM NO.	PART NUMBER	DESCRIPTION	Default/QTY.
1	13090780-02	ELECTRODE, BRAZED	1
2	13090816-01	CABLE CONTROL M9-500	1
3	130901122-02	TRIM POT ASSY M9-500	1
4	130901120-01	COVER HOUSING ASSY M9-500	1
5	130905164-01	LATCH ASSY M9-500	2
6	13090651-01	MOTOR DRIVE 20RPM	1
7	13090652-01	GEAR PINION COUPLING TYPE	1
8	13090654-02	IDLER GEAR ASSY	1
9	130905136-01	GROUND STRAP CONN-BRZD M9-500	1
10	140905215-01	LIST SELECT M9-500 CLAMPS	1
11	42090645-01	ROTOR GEAR M9-500	1
12	42090654-02	COUPLING INSULATING M9	1
13	42090654-03	SPACER SPRING .391D .49D .20LG	1
14	13090668-01	GEAR, IDLER, STAINLESS M9-500	2
15	420901100-01	COVER POT	1
16	420901100-02	COVER SWITCH M9-500	1
17	420901101-01	HANDLE M9-500	2
18	420901102-01	NIPPLE GAS	1
19	42090198-01	MAIN HOUSING M9-500	1
20	420907241-01	BACKING PLATE	1
21	420905292-05	GROUND STRAP M9-500	1
22	420905292-09	GAUGE LOCATING M9-500	1
23	OO-86	SPRING CPRSN .48D .37L .035W	1
24	TUNGSTEN	ELECTRODE (REF)	1
25	SIL08-32-0,12NY	SCREW BHD SLT 8-32 1/8 NYL	1
26	420905334-02	PLATE BACKING QUICK RELEASE	1
27	MMGGD1W2C	SWITCH LIMIT ROLLER	1
28	W02SS-FL	WASHER FLAT #2 SET	1
29	SCS02-56-0.18NP	SCREW CAP SKT 2-56 3/16L	1
30	SFL02-56-0.25NY	SCREW FLH SLT 2-56 1/4L	2
31	SFL02-56-0.18NP	SCREW FLH SLT 2-56 3/16L	2
32	SCS02-56-0,31NP	SCREW CAP SKT 2-56 5/16L	2
33	SPL02-56-0.31NP	SCREW PNH SLT 2-56 5/16L	1
34	SFL02-56-0.31NP	SCREW FLH SLT 2-56 5/16L	2
35	SFL02-56-0,31NY	SCREW FLH SLT 2-56 5/16L	2
36	SCS04-40-0.25NP	SCREW CAP SKT 4-40 1/4 L	2
37	SFS04-40-0,37NP	SCREW FLH SKT 4-40 3/8 L	4
38	SFS04-40-0.87NP	SCREW FLH SKT 4-40 7/8L	2
39	SCS08-32-0.18NP	SCREW CAP SKT 8-32 3/16L	2
40	SIL01-72-0.12SS	SCREW BHD SLT 1-72 1/8L	3
41	44D11	SCREW SHLDR SKT 4-40 1/4 L	2
42	7051	CONN 5 PIN MALE SUB-MINUTURE BLK W/GOLD PINS	1
43	M23053/5-107-0	TUBING SHRINK 3/8 ID BLK	3

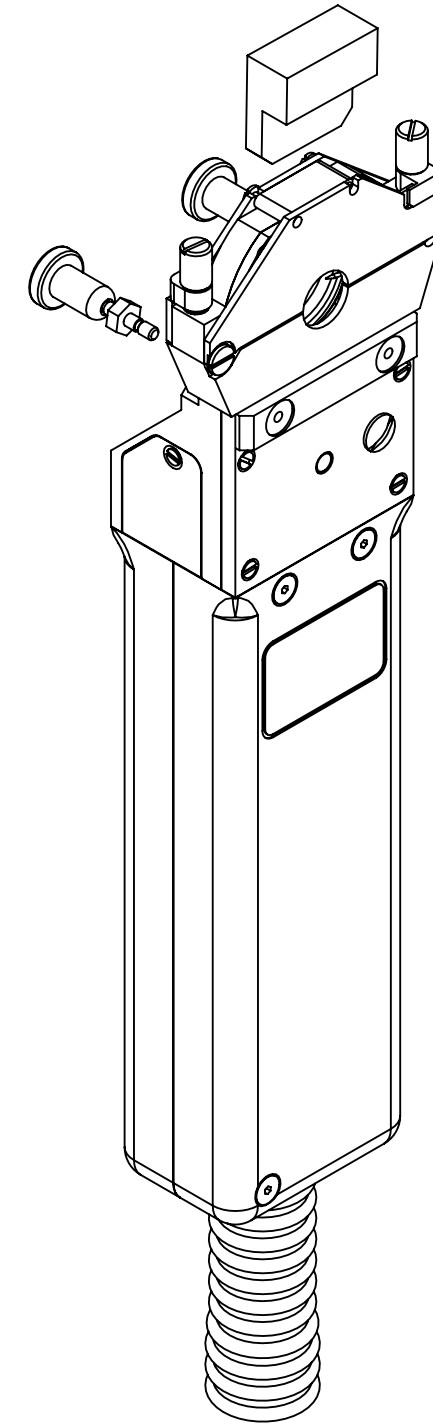

MODEL 9-500
IPB 090141
WELD HEAD BASIC ASSEMBLY

FOR REFERENCE ONLY

THIS DOCUMENT OR DRAWING AND THE INFORMATION CONTAINED HEREIN IS THE PROPERTY OF ARC MACHINES, INC., IS PROPRIETARY, IS SUBMITTED AND RECEIVED IN CONFIDENCE, SHALL BE USED ONLY FOR THE PURPOSE FOR WHICH IT IS SUBMITTED AND SHALL NOT BE COPIED IN WHOLE OR IN PART WITHOUT THE PRIOR EXPRESS WRITTEN PERMISSION OF ARC MACHINES, INC.



ITEM NO.	PART NUMBER	DESCRIPTION	Default/ QTY.
1	130905210-01	KIT M9-500 QUICK REL FOR TCA-MCA-UCA	1
2	130901135-01	COVER HOUSING ASSY M9-500C	1
3	13090651-01	MOTOR DRIVE 20RPM	1
4	140905219-01	LIST SELECT M9-500 CLAMPS	1
5	13090652-01	GEAR PINION COUPLING TYPE	1
6	130905136-01	GROUND STRAP CONN-BRZD M9-500	1
7	130907127-01	CONDUCTOR SHOE BRZD M9-500C	1
8	130901122-02	TRIM POT ASSY M9-500	1
9	13090658-02	DRIVE GEAR ASSY	1
10	420901136-01	MAIN HOUSING M9-500C	1
11	42090948-01	HANDLE M9-500C	2
12	13090668-01	GEAR, IDLER, STAINLESS M9-500	2
13	42090665-01	ROTOR GEAR M9-500C	1
14	42090600-06	SCREW M9-500C ELECTRODE	3
15	420907241-01	BACKING PLATE	1
16	420901102-01	NIPPLE GAS	1
17	420901100-02	COVER SWITCH M9-500	1
18	420901100-01	COVER POT	1
19	42090654-02	COUPLING INSULATING M9	1
20	42090654-03	SPACER SPRING .391D .49D .20LG	1
21	OO-86	SPRING CPRSN .48D .37L .035W	1
22	SIL08-32-0,12NY	SCREW BHD SLT 8-32 1/8 NYL	1
23	13090836-01	CABLE M9-500C S-ASSY	1
24	MMGGD1W2C	SWITCH LIMIT LEAF ROLLER	1
25	SCS02-56-0,31NP	SCREW CAP SKT 2-56 5/16L	2
26	W02SS-FL	WASHER FLAT #2 SET	1
27	SPL02-56-0.31NP	SCREW PNH SLT 2-56 5/16L	1
28	SFS04-40-0.37NP	SCREW FLH SKT 4-40 3/8L	4
29	SFS04-40-0.87NP	SCREW FLH SKT 4-40 7/8L	2
30	SCS08-32-0.18NP	SCREW CAP SKT 8-32 3/16L	1
31	SCS02-56-0.18NP	SCREW CAP SKT 2-56 3/16L	1
32	SFL02-56-0.31NP	SCREW FLH SLT 2-56 5/16L	2
33	SFL02-56-0.18NP	SCREW FLH SLT 2-56 3/16L	2
34	SFL02-56-0.25NY	SCREW FLH SLT 2-56 1/4L NY	2
35	SCS04-40-0.25NP	SCREW CAP SKT 4-40 1/4 L	2
36	SFL02-56-0,31NY	SCREW FLH SLT 2-56 5/16L NY	2
37	TUNGSTEN	ELECTRODE (REF)	1

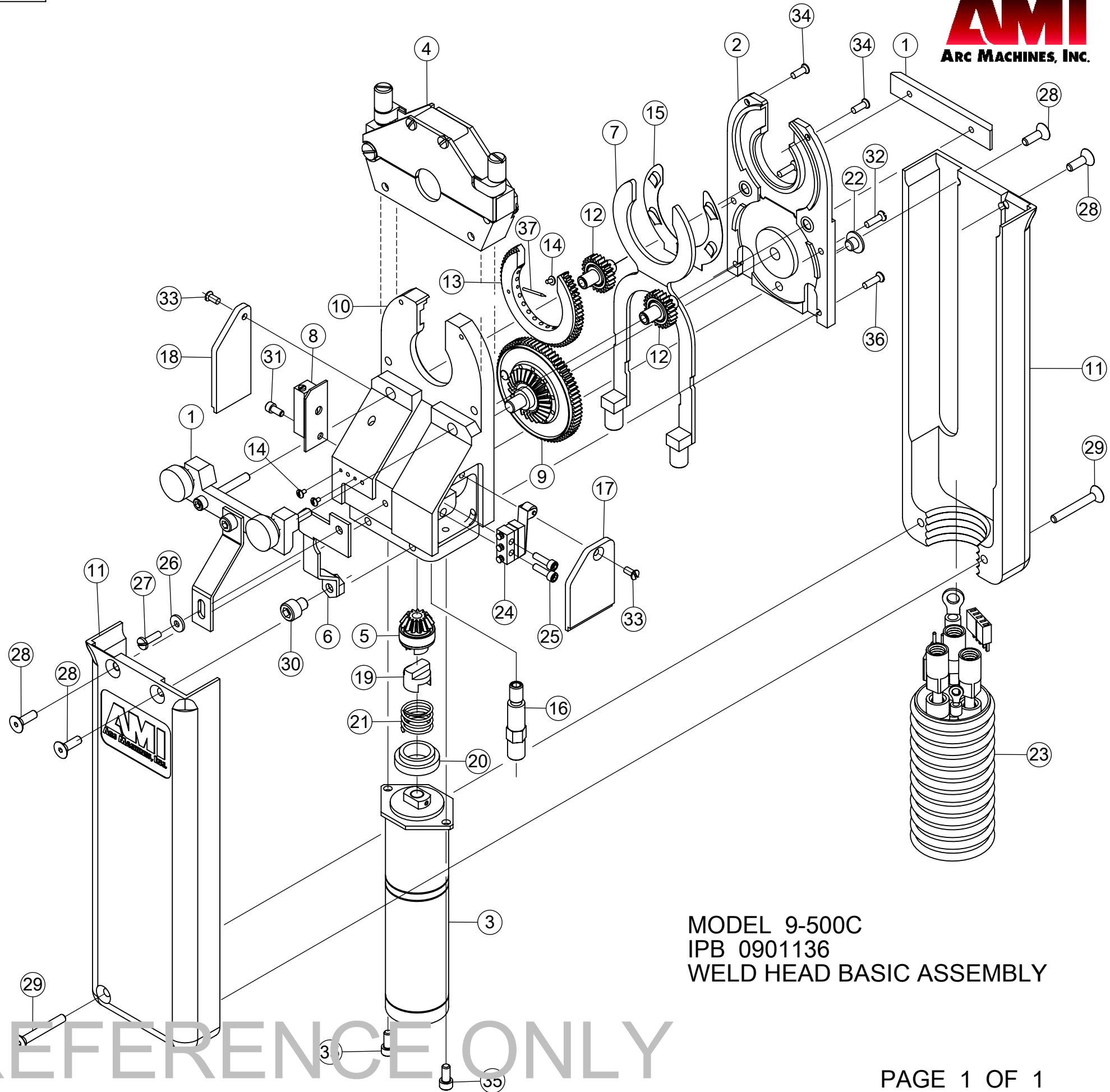

MODEL 9-500C
IPB 0901136
WELD HEAD BASIC ASSEMBLY

TO ORDER USE PART NUMBER.
PRICE, PART NUMBER AND DESCRIPTION
SUBJECT TO CHANGE WITHOUT NOTICE.

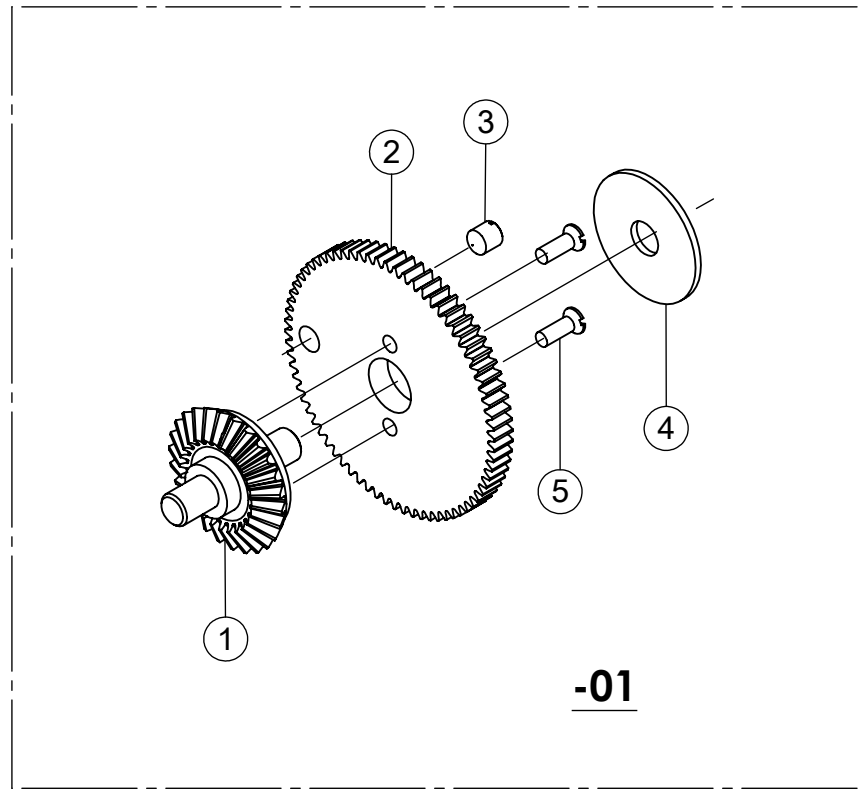

ITEM NO.	PART NUMBER	DESCRIPTION	-01/QTY.	-02/QTY.
1	13090655-01	GEAR AND SHAFT ASSEMBLY	1	1
2	42090664-01	GEARDRIVE, PHENOLIC	1	1
3	42090647-10	ACTUATOR SWITCH .16 LG	1	1
4	5610-103-40	WASHER NYLON .75 OD .19 ID .040 THK	1	1
5	SFL02-56-0.25SS	SCREW FLH SLT 2-56 1/4L	2	2
6	22090699-01	PLATE, INSULATING, DRIVE	-	1

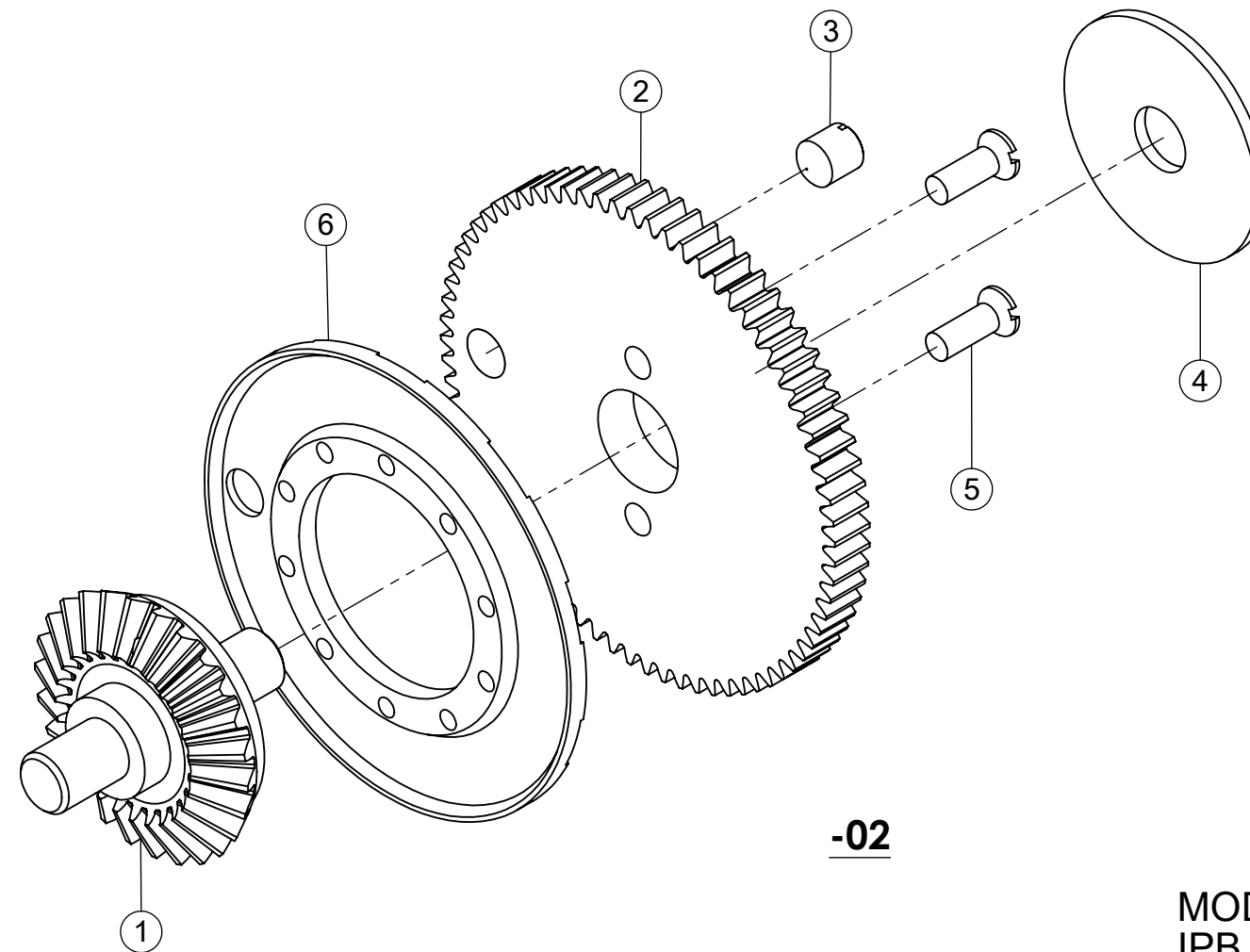

MODEL 9-500C
 IPB 090658
 DRIVE GEAR ASSEMBLY
 (REPAIRABLE)

ISSUED: 25 JAN 2005
 REVISED: 08 MAY 2012

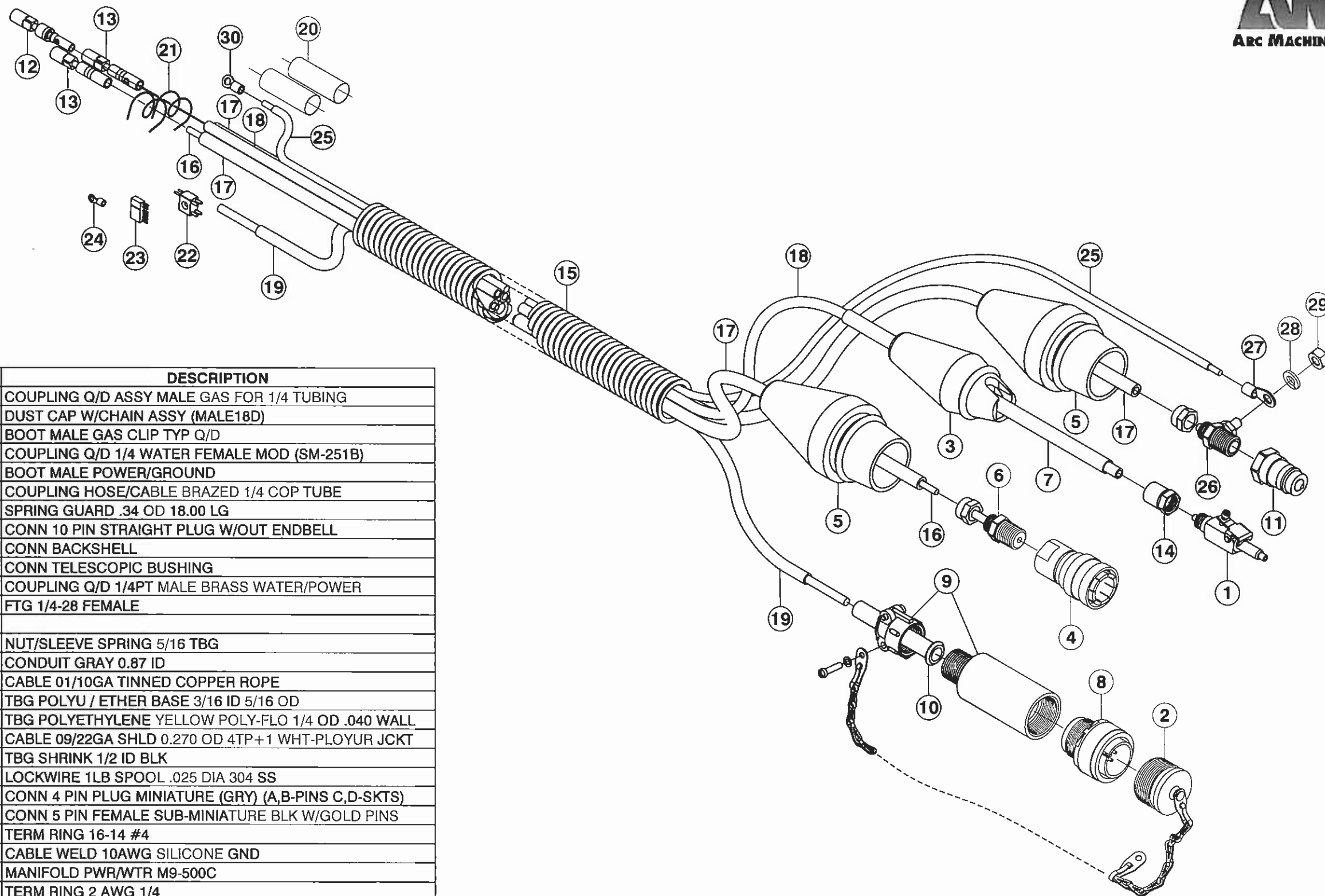

ITEM NO.	QTY.	PART NO.	DESCRIPTION
1	1	1351109-01	COUPLING Q/D ASSY MALE GAS FOR 1/4 TUBING
2	1	1350110-04	DUST CAP W/CHAIN ASSY (MALE18D)
3	1	42060805-04	BOOT MALE GAS CLIP TYP Q/D
4	1	42060800-02	COUPLING Q/D 1/4 WATER FEMALE MOD (SM-251B)
5	2	42060804-01	BOOT MALE POWER/GROUND
6	1	13090837-01	COUPLING HOSE/CABLE BRAZED 1/4 COP TUBE
7	1	AS200718	SPRING GUARD .34 OD 18.00 LG
8	1	MS3106E18-1PF42	CONN 10 PIN STRAIGHT PLUG W/OUT ENDBELL
9	1	G1501N186A3A	CONN BACKSHELL
10	1	MS39056-3	CONN TELESCOPIC BUSHING
11	1	SM-252B	COUPLING Q/D 1/4PT MALE BRASS WATER/POWER
12	1	2PF1	FTG 1/4-28 FEMALE
13	2	ARC-1881	
14	1	261-PG-05	NUT/SLEEVE SPRING 5/16 TBG
15	1	DUCT-0,87-50-G	CONDUIT GRAY 0.87 ID
16	1	NER7-59-36T	CABLE 01/10GA TINNED COPPER ROPE
17	2	42060814-02	TBG POLYU / ETHER BASE 3/16 ID 5/16 OD
18	1	44-P-YELLOW	TBG POLYETHYLENE YELLOW POLY-FLO 1/4 OD .040 WALL
19	1	CWT11943	CABLE 09/22GA SHLD 0.270 OD 4TP+1 WHT-PLOYUR JCKT
20	2	M23053/5-108-0	TBG SHRINK 1/2 ID BLK
21	2	MS20995C25	LOCKWIRE 1LB SPOOL .025 DIA 304 SS
22	1	JF2P2SCD	CONN 4 PIN PLUG MINIATURE (GRY) (A,B-PINS C,D-SKTS)
23	1	7052	CONN 5 PIN FEMALE SUB-MINIATURE BLK W/GOLD PINS
24	1	34119	TERM RING 16-14 #4
25	1	AS105-4-BLK	CABLE WELD 10AWG SILICONE GND
26	1	13090837-02	MANIFOLD PWR/WTR M9-500C
27	1	B-3284	TERM RING 2 AWG 1/4
28	1	W25BR-LK-SP	WASHER LOCK SPT 1/4 BRS
29	1	BH25-20-0.37BR	BOLT HEX 1/4-20 3/8 L BR
30	1	322454	TERM RING 22-16 #6

MODEL 9-500C
IPB 090836
CABLE ASSEMBLY

ISSUED: 21 MAR 2002
REVISED: 1 FEB 2005

FOR REFERENCE ONLY

PAGE 1 OF 1

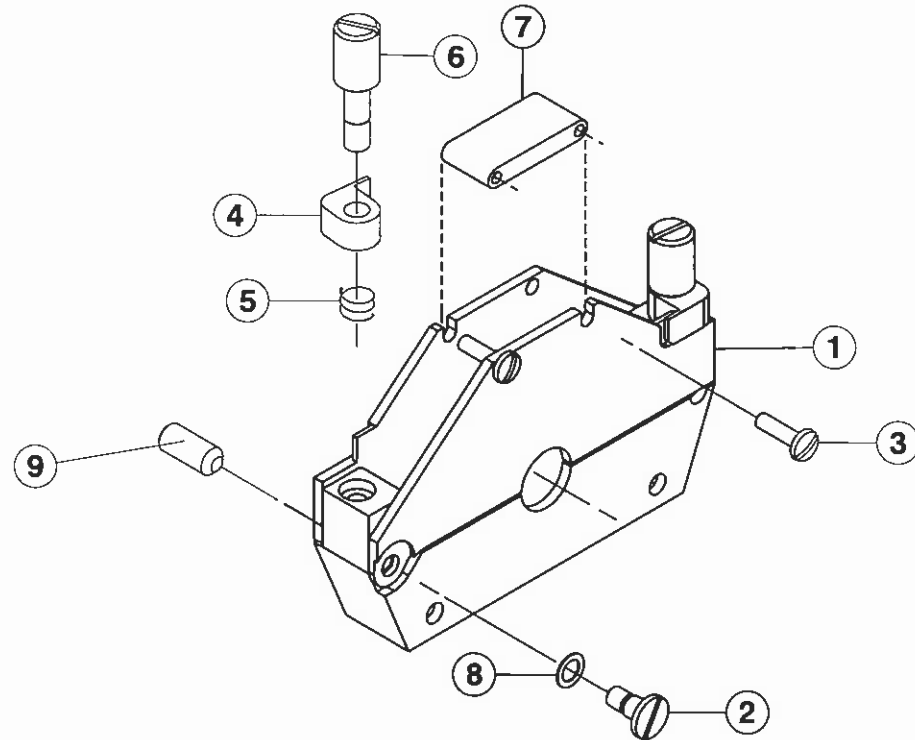

CLAMP ASSEMBLY DETAILS
(TYPICAL ALL CLAMP ASSEMBLIES)

ITEM NO.	QTY.	PART NO.	DESCRIPTION
1	1	CLAMP ASSY	(REF.)
2	2	420905360-06	SHOULDER SCREW MOD (43D10)
3	2	SIL02-56-0,37SS	SCREW BDH SLT 2-56 3/8 L
4	2	420905360-05	SWING CLAMP
5	2	00-60	SPRING
6	2	420905360-04	THUMB SCREW
7	1	420905360-07	WINDOW FLIP-UP
8	1	MW0183-004-S	WAVE WASHER
9	2	SSFLATSKT 0.164-32x0.375-HX-N	SCREW SET SKT 2-56 1/8 L FLHD

MODEL 9-500
IPB 090511
CLAMP ASSEMBLY

ISSUED: 2 MAY 1990
REVISED: 26 JAN 2005

FOR REFERENCE ONLY

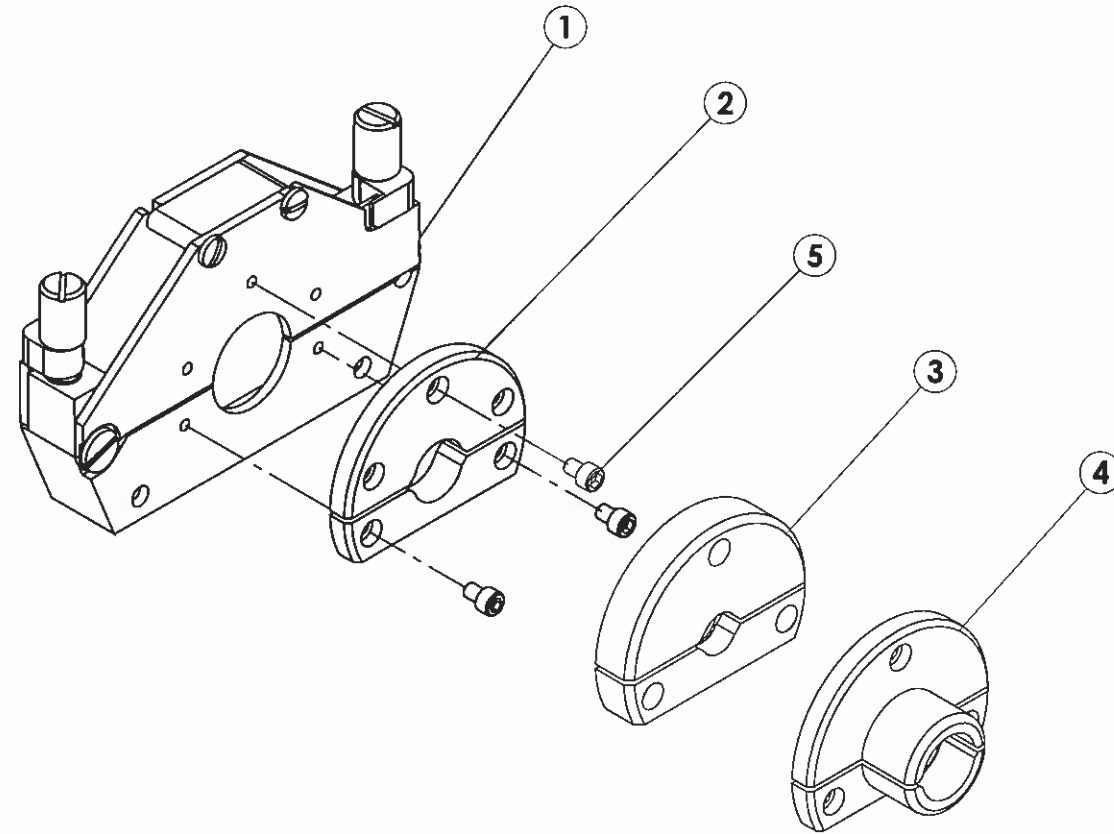

ITEM NO.	PART NUMBER	DESCRIPTION	QTY.
1	130905217-XX	MODIFIED CLAMP ASSEMBLY	1
2	420905270-05	STANDARD TUBE INSERT	1
3	420905268-01	AUTOMATIC FITTING INSERT (PARKER-HANNIFIN)	1
4	420905269-02	AUTOMATIC FITTING INSERT (CAJON)	1
5	SCS02-56-0,12NP	SCREW CAP SKT 2-56 1/8 L	3

TO ORDER USE PART NUMBER.
PRICE, PART NUMBER AND DESCRIPTION
SUBJECT TO CHANGE WITHOUT NOTICE.

FOR REFERENCE ONLY

MODEL 9-500
IPB 0905217
MODIFIED CLAMP ASSY (MCA)
W/ CLAMP INSERTS

ISSUED: 2 MAY 1990
REVISED: 26 OCT 2007

PAGE 1 OF 1

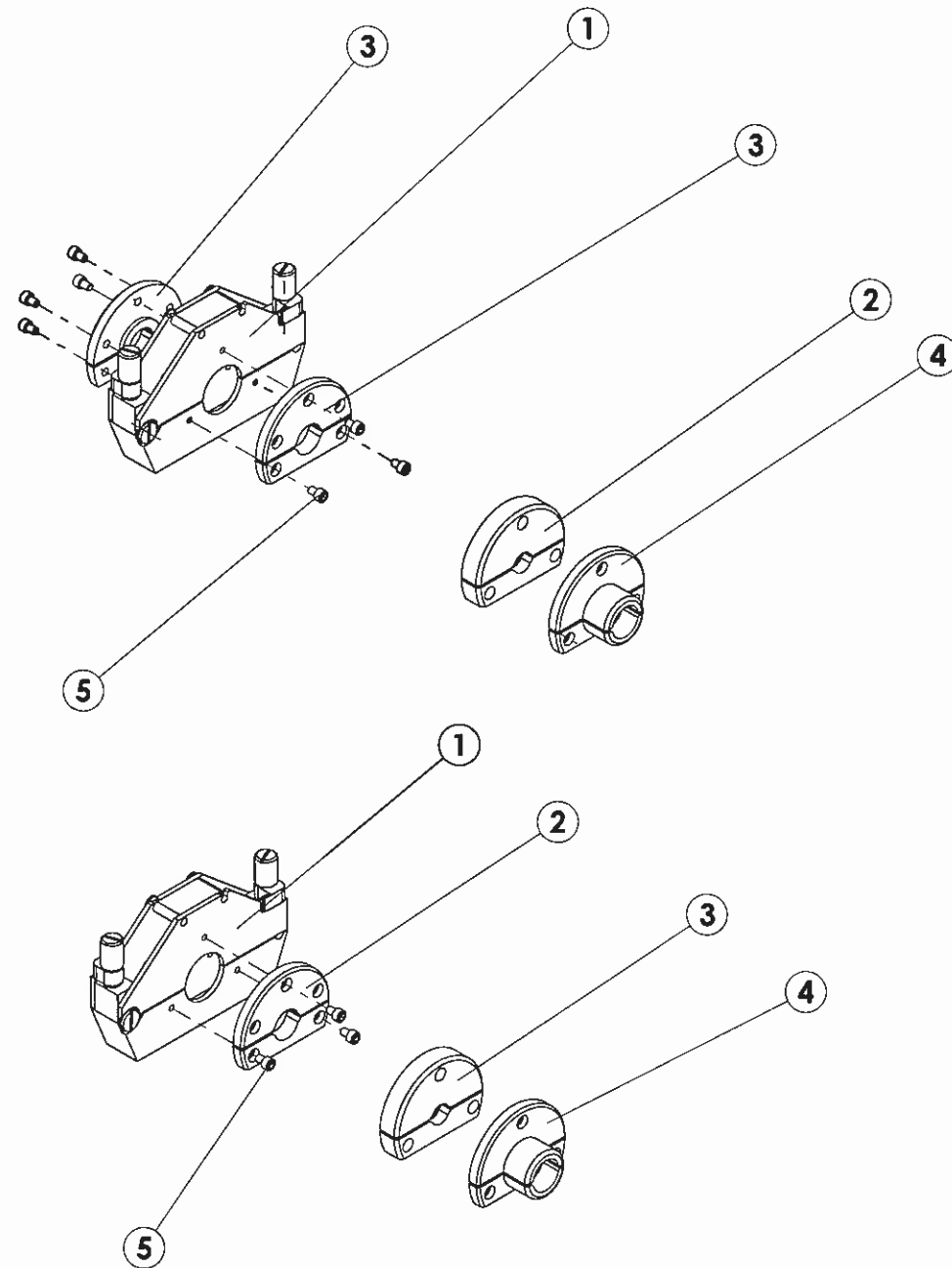

ITEM NO.	PART NUMBER	DESCRIPTION	QTY.
1	130905216-XX	UNIVERSAL CLAMP ASSEMBLY	1
2	420905268-01	AUTOMATIC FITTING INSERT (PARKER-HANNIFIN)	1
3	420905270-05	STANDARD TUBE INSERT	2
4	420905269-02	AUTOMATIC FITTING INSERT (CAJON)	1
5	SCS02-56-0,12NP	SCREW CAP SKT 2-56 1/8 L	7

ITEM NO.	PART NUMBER	DESCRIPTION	QTY.
1	130905216-XX	UNIVERSAL CLAMP ASSEMBLY	1
2	420905270-05	STANDARD TUBE INSERT	1
3	420905268-01	AUTOMATIC FITTING INSERT (PARKER-HANNIFIN)	1
4	420905269-02	AUTOMATIC FITTING INSERT (CAJON)	1
5	SCS02-56-0,12NP	SCREW CAP SKT 2-56 1/8 L	3

MODEL 9-500
IPB 0905216
UNIVERSAL CLAMP ASSY (UCA)
W/ CLAMP INSERTS

ISSUED: 2 MAY 1990
REVISED: 26 OCT 2007

TO ORDER USE PART NUMBER.
PRICE, PART NUMBER AND DESCRIPTION
SUBJECT TO CHANGE WITHOUT NOTICE.

FOR REFERENCE ONLY

PAGE 1 OF 1

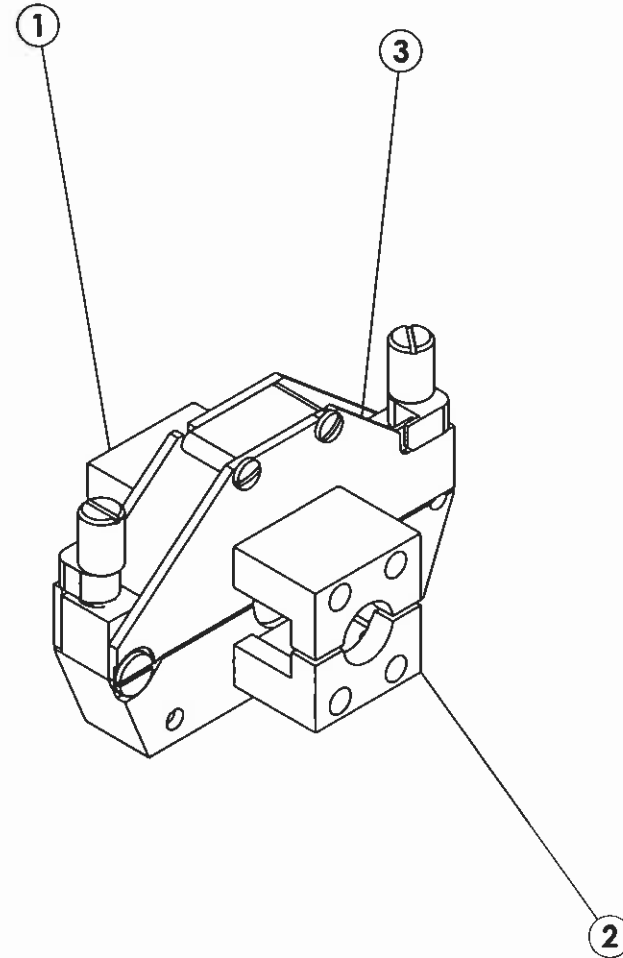

ITEM NO.	PART NUMBER	DESCRIPTION	QTY.
1	420905385-02	MINI CUBE	1
2	420905390-02	MINI CUBE ADJUSTABLE	1
3	130905245-XX	TUBE CLAMP ASSY	1

Model 9-500
IPB 0905245
TUBE CLAMP ASSY (TCA-2) W/ MINI
CUBE AND MINI CUBE ADJUSTABLE

ISSUED:
REVISED: 26 OCT 2007

TO ORDER USE PART NUMBER.
PRICE, PART NUMBER AND DESCRIPTION
SUBJECT TO CHANGE WITHOUT NOTICE.

FOR REFERENCE ONLY

PAGE 1 OF 1

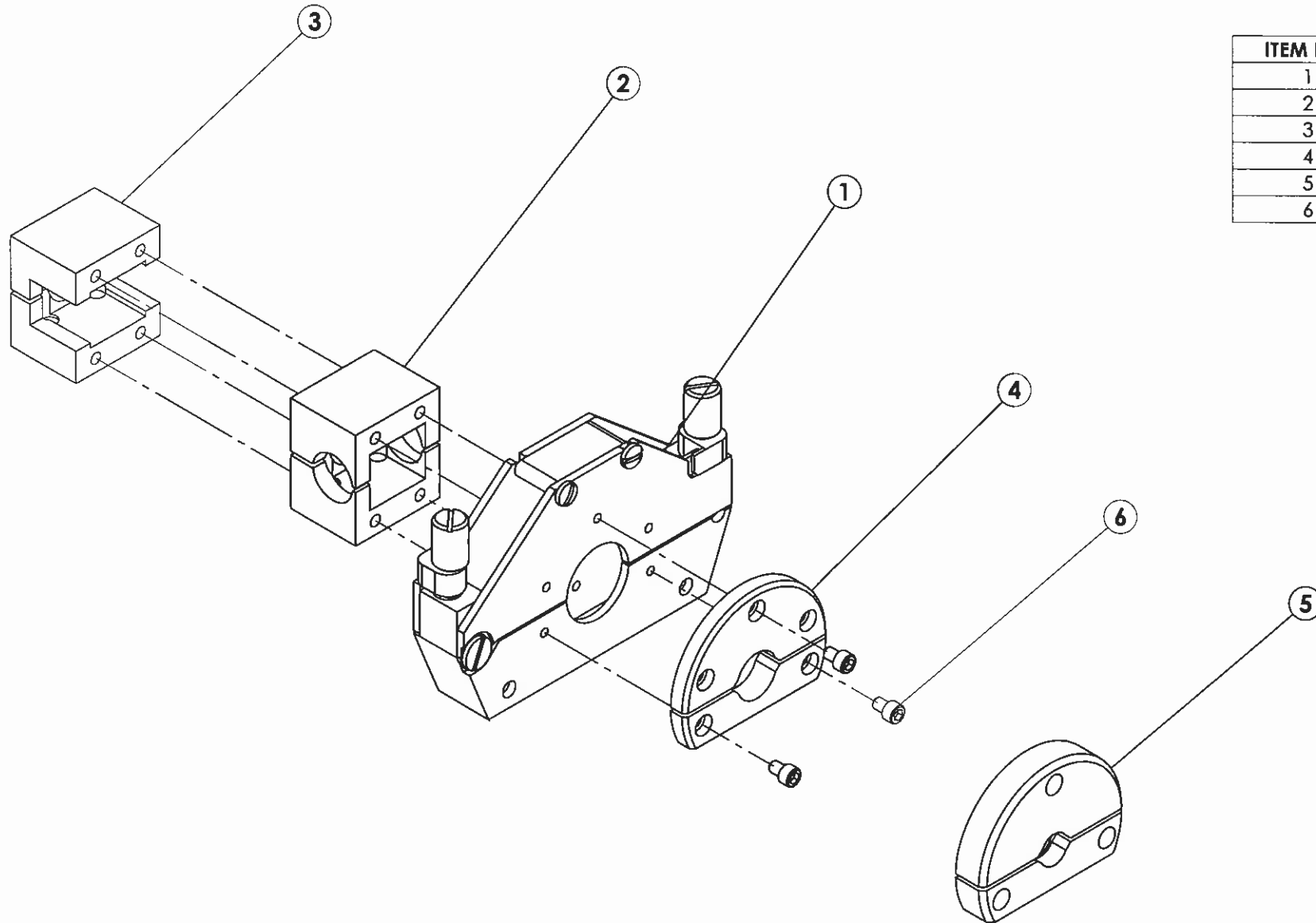

ITEM NO.	PART NUMBER	DESCRIPTION	QTY.
1	410905246-XX	MODIFIED CLAMP ASSEMBLY	1
2	420905385-02	MINI CUBE	1
3	420905390-02	MINI CUBE ADJUSTABLE	1
4	420905270-05	STANDARD TUBE INSERT	1
5	420905268-01	AUTOMATIC FITTING INSERT (PARKER-HANNIFIN)	1
6	SCS02-56-0,12NP	SCREW CAP SKT 2-56 1/8 L	3

TO ORDER USE PART NUMBER.
PRICE, PART NUMBER AND DESCRIPTION
SUBJECT TO CHANGE WITHOUT NOTICE.

FOR REFERENCE ONLY

MODEL 9-500
IPB 0905246
MODIFIED CLAMP ASSY (MCA-2) W/
MINI CUBES AND CLAMP INSERTS

ISSUED:
REVISED: 26 OCT 2007

PAGE 1 OF 1

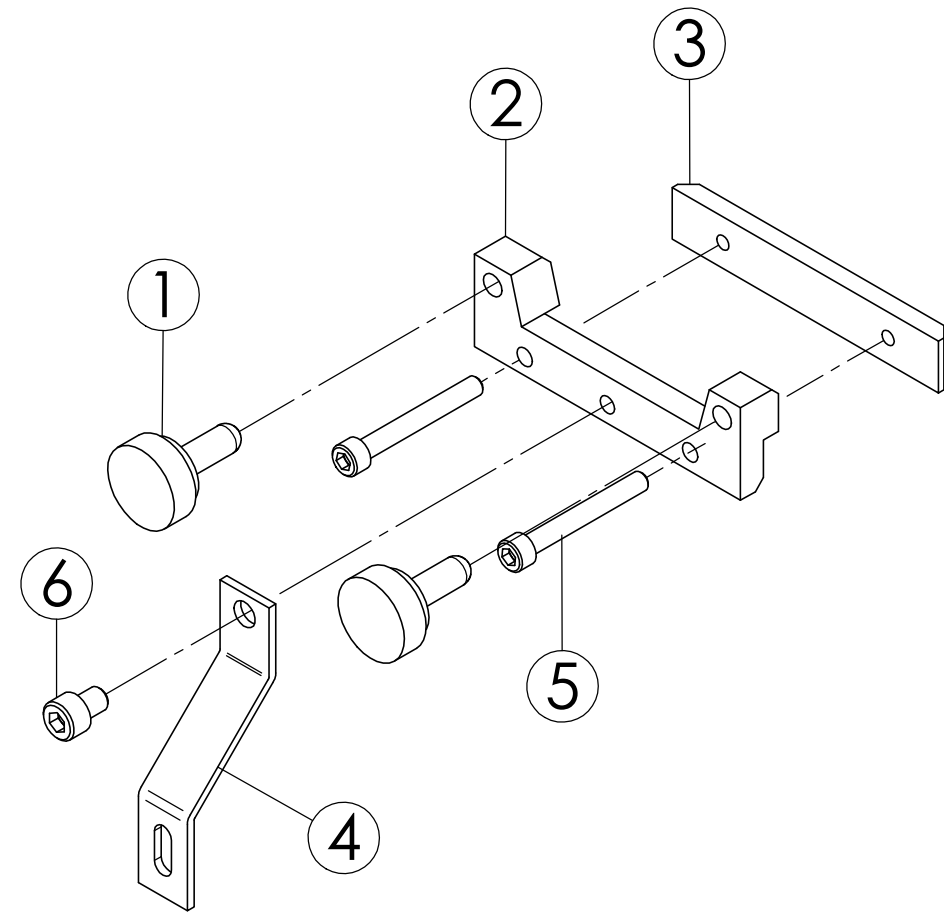
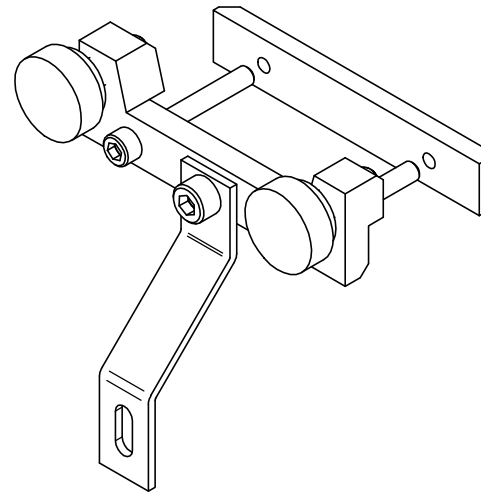

ITEM NO	QTY	PART NO.	DESCRIPTION
1	2	130905211-01	SCREW THUMB
2	1	420905334-01	PLATE HOLD DOWN QUICK RELEASE
3	1	420905334-02	PLATE BACKING QUICK RELEASE
4	1	420905335-01	GROUND STRAP QUICK RELEASE
5	2	SCS04-40-0,87NP	SCREW CAP SKT 4-40 7/8L
6	1	SCS06-31-0,18NP	SCREW CAP SKT 6-32 3/16L

MODEL 9-500
IPB 0905210
KIT CONVERSION QUICK RELEASE
FOR TCA-MCA-UCA (OPTION)

ISSUED: ISSUED 22 JAN 2005
REVISED:

TO ORDER USE PART NUMBER.
PRICE, PART NUMBER AND DESCRIPTION
SUBJECT TO CHANGE WITHOUT NOTICE.

FOR REFERENCE ONLY

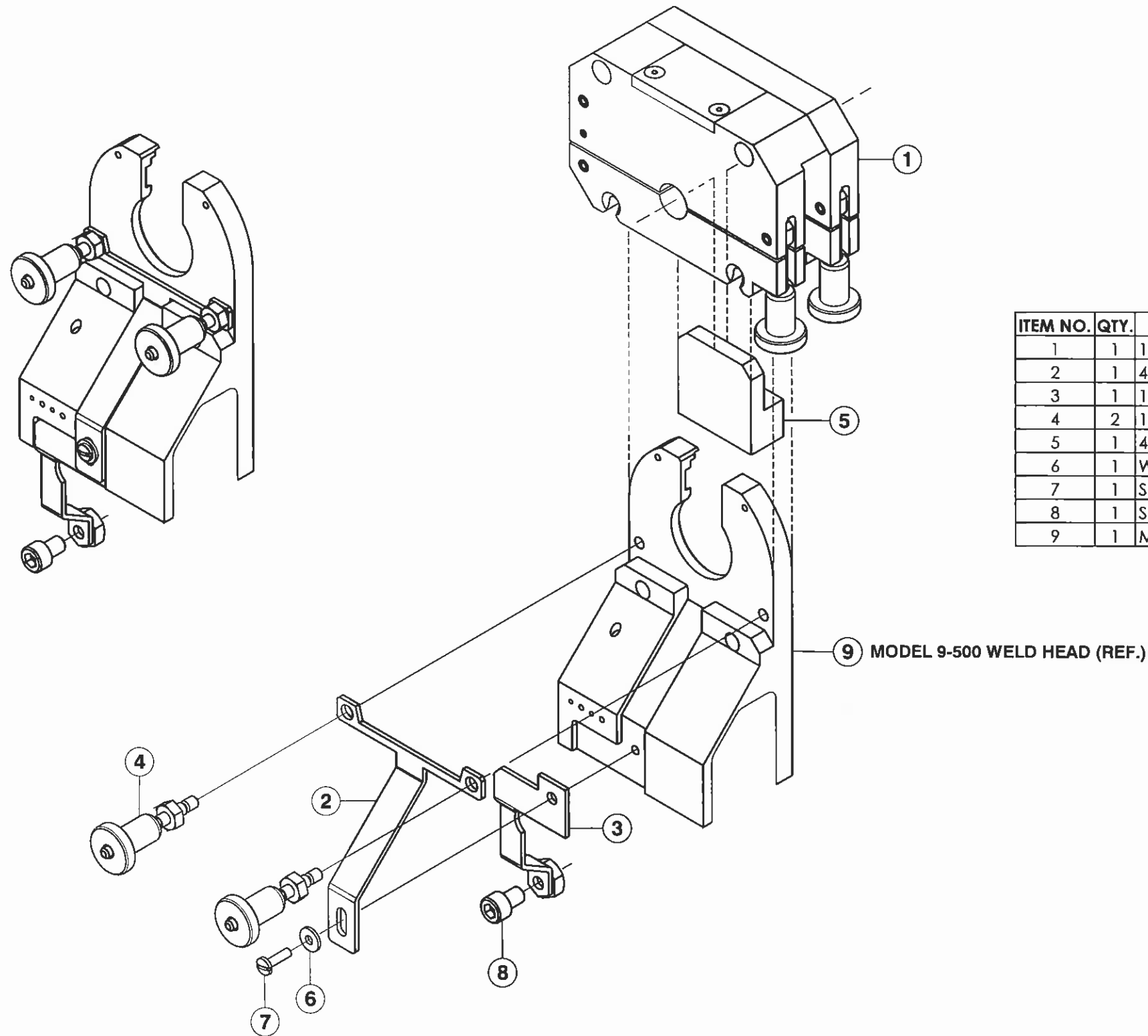

ITEM NO.	QTY.	PART NO.	DESCRIPTION
1	1	140905137-01	LIST SELECT M9-500 CLAMP CASSETTE
2	1	420905292-05	GROUND STRAP M9-500
3	1	130905136-01	GROUND STRAP CONN-BRZD M9-500
4	2	130905164-01	LATCH SCREW AND KNOB ASSY
5	1	420905292-09	GAUGE LOCATING M9-500
6	1	W02SS-FL	WASHER FL #2 SST
7	1	SPL02-56-0.31NP	SCREW PNH SLT 2-56 5/16 L
8	1	SCS08-32-0,25NP	SCREW CAP SKT 8-32 1/4 L
9	1	MODEL 9-500 WELD HEAD	(REF.)

NOTE: KIT REQUIRED FOR WELD HEAD SERIAL NO.7503 AND LOWER.
TO ORDER SASSETTE MODULE KIT SPECIFY TYPE AND WELD SIZE (O.D.).
FOR CONVERSION INSTRUCTIONS M9-500 TO M9CT-500 SEE DWG#750026.

MODEL 9-500
IPB 0905138
KIT CONVERSION TO MODEL 9CT-500
(OPTION)

ISSUED: 25 OCT 1989
REVISED: 3 FEB 2005

TO ORDER USE PART NUMBER.
PRICE, PART NUMBER AND DESCRIPTION
SUBJECT TO CHANGE WITHOUT NOTICE.

FOR REFERENCE ONLY

PAGE 1 OF 1

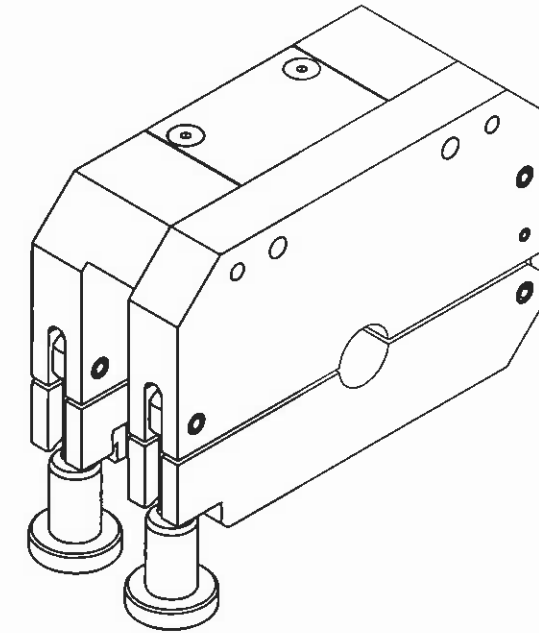
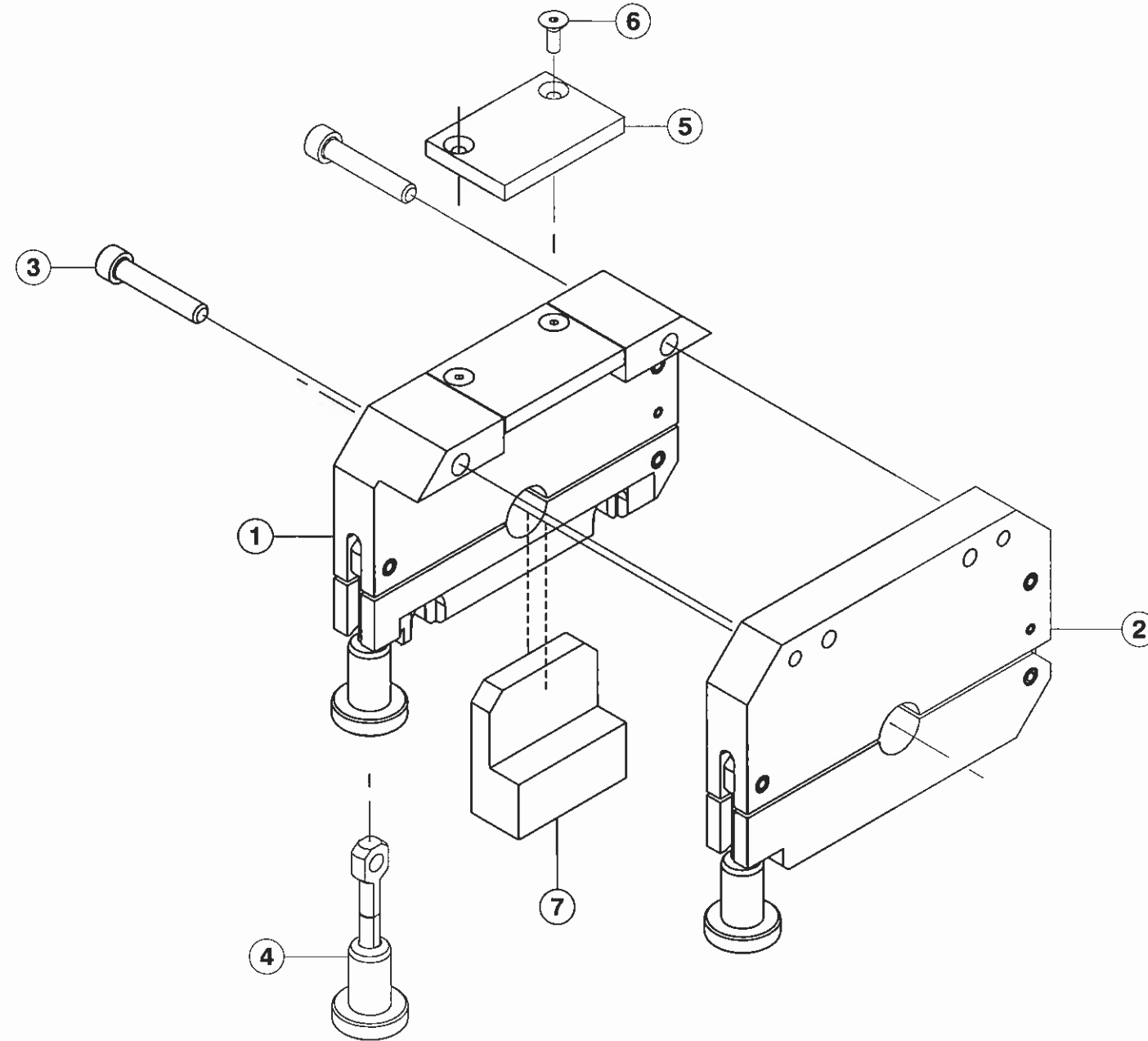

ITEM NO.	QTY.	PART NO.	DESCRIPTION
1	1	130905173-XX	CASSETTE CLAMP HSG SIDE ASSY
2	1	130905174-XX	CASSETTE CLAMP HSG SIDE
3	2	SCS06-32-0,75NP	SCREW CAP SKT 6-32 3/4 L
4	1	13090569-01	LATCH ASSY
5	1	420905292-02	WINDOW
6	1	SFS02-56-0.25NP	SCREW FLH SKT 2-56 1/4 L
7	1	420905292-09	GAUGE LOCATING M9-500

NOTE: TO ORDER TUBE TO TUBE CASSETTE MODULES SPECIFY WELD SIZE

MODEL 9-500
IPB 0905135-01
TUBE TO TUBE CASSETTE MODULE ASSEMBLY

ISSUED: 1 FEB 2005
REVISED:

TO ORDER USE PART NUMBER.
PRICE, PART NUMBER AND DESCRIPTION
SUBJECT TO CHANGE WITHOUT NOTICE.

FOR REFERENCE ONLY

PAGE 1 OF 1

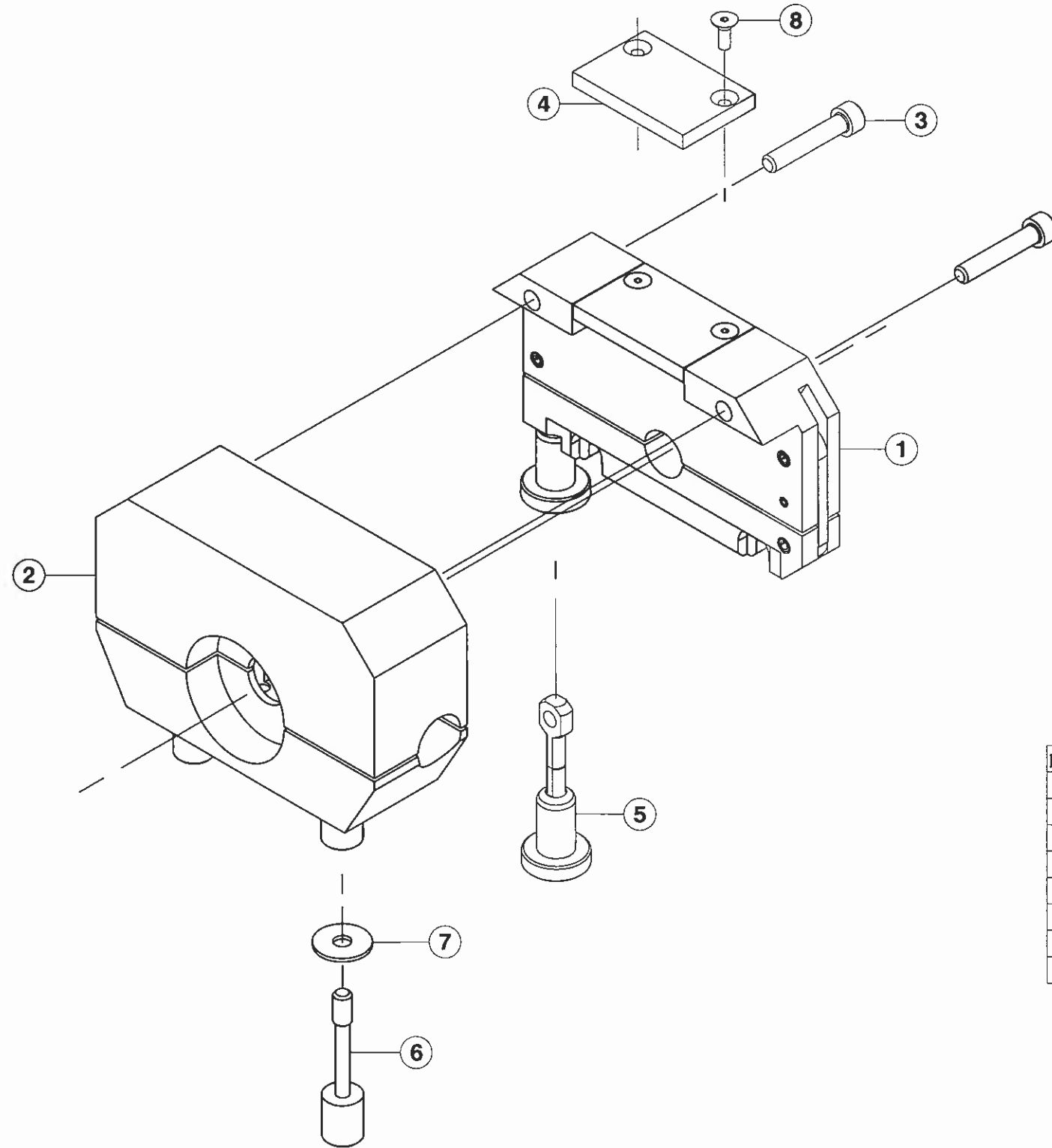

ITEM NO.	QTY.	PART NO.	DESCRIPTION
1	1	130905173-XX	CASSETTE CLAMP HSG SIDE ASSY
2	1	130905175-XX	CLAMP COVER SIDE ASSY
3	2	SCS06-32-0,75NP	SCREW CAP SKT 6-32 3/4 L
4	1	420905292-02	WINDOW
5	1	13090569-01	LATCH ASSY
6	1	420905292-08	CAPTIVE SCREW (PQH-11)
7	1	5710-22-30	WASHER FL .14ID .43D .030T SST
8	1	SFS02-56-0.25NP	SCREW FLH SKT 2-56 1/4 L

NOTE: TO ORDER TUBE TO FITTING CASSETTE MODULES SPECIFY WELD / FITTING O.D.

MODEL 9-500
IPB 0905135-02
TUBE TO FITTING CASSETTE MODULE ASSEMBLY

ISSUED: 1 FEB 2005
 REVISED:

TO ORDER USE PART NUMBER.
 PRICE, PART NUMBER AND DESCRIPTION
 SUBJECT TO CHANGE WITHOUT NOTICE.

FOR REFERENCE ONLY

PAGE 1 OF 1

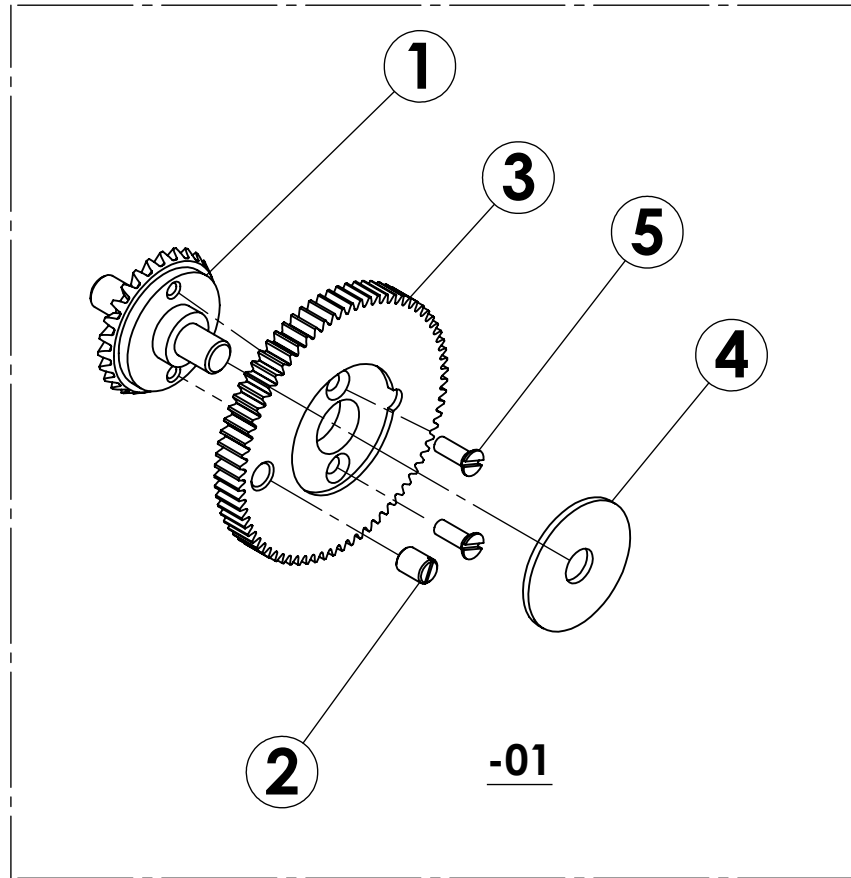

ITEM NO.	PART NUMBER	DESCRIPTION	-01/QTY.	-02/QTY.
1	13090655-01	GEAR AND SHAFT ASSEMBLY	1	1
2	42090647-09	ACTUATOR SWITCH	1	1
3	42090660-01	GEAR DRIVE PHENOLIC	1	1
4	5610-103-40	WASHER NYLON .75 OD .19 ID .040 THK	1	1
5	SFL02-56-0.25SS	SCREW FLH SLT 2-56 1/4L	2	2
6	22090699-01	PLATE, INSULATING, DRIVE	-	1

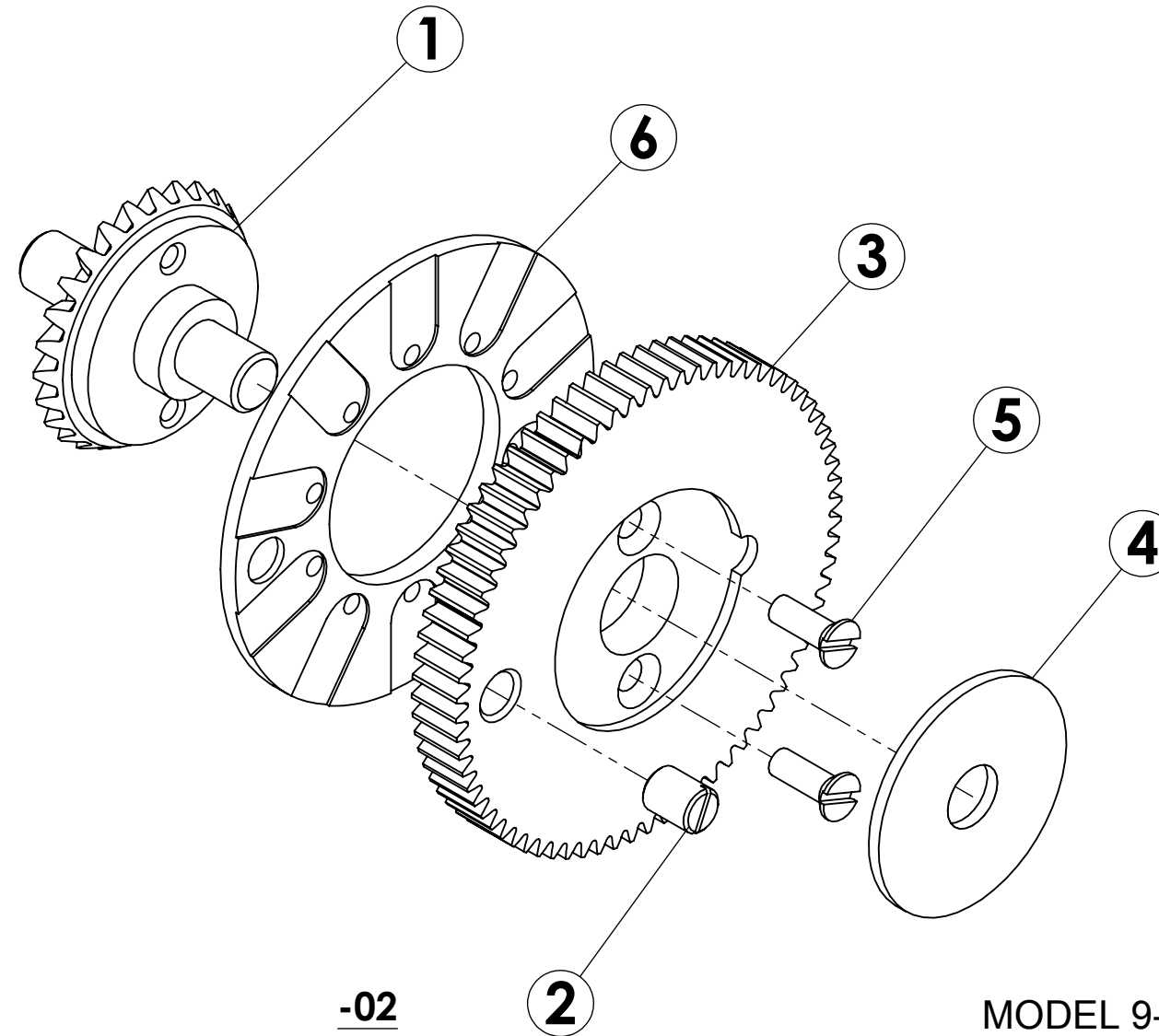

MODEL 9-500
 IPB 090654
 DRIVE GEAR ASSEMBLY
 (REPAIRABLE)

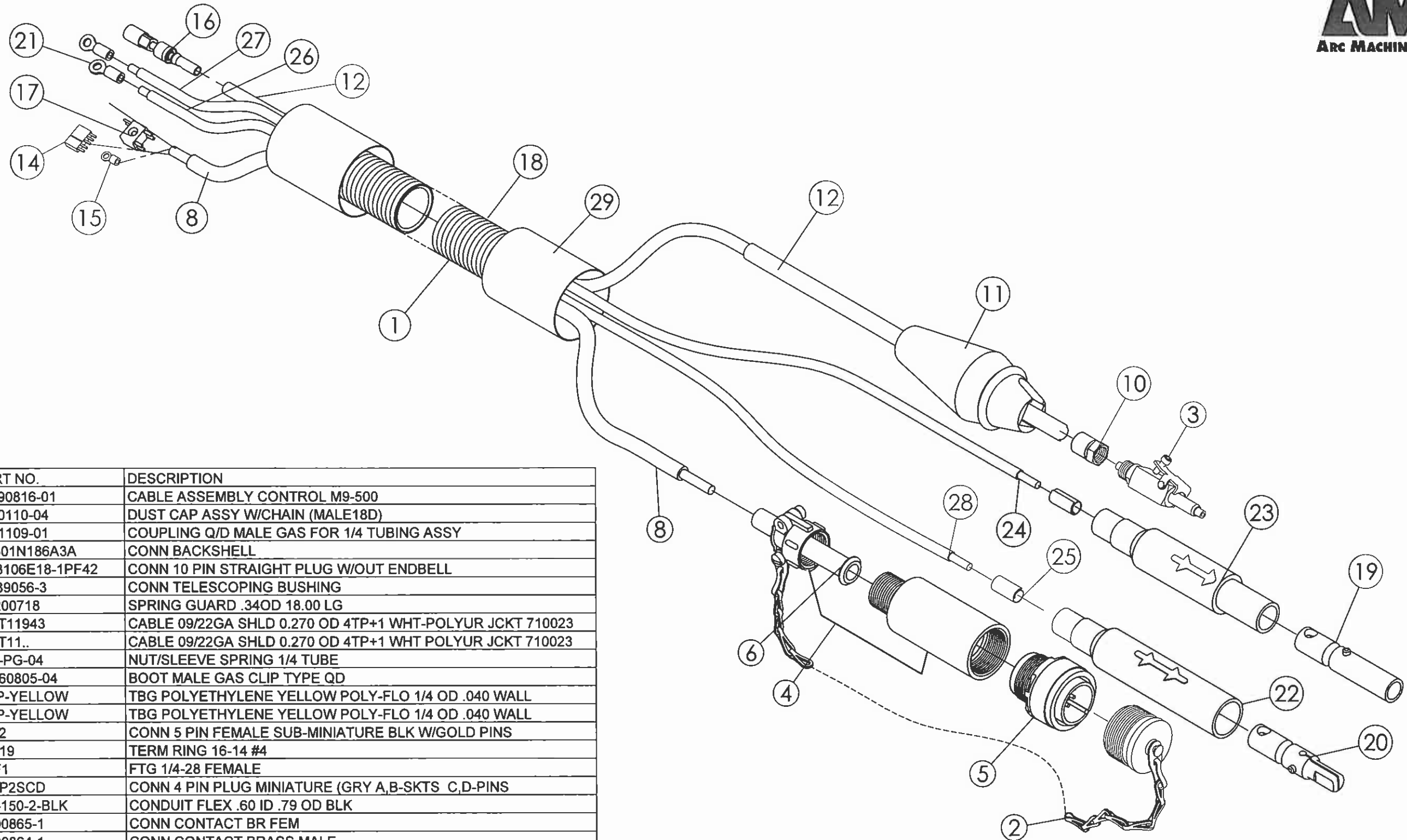

ITEM NO.	QTY.	PART NO.	DESCRIPTION
1	1	13090816-01	CABLE ASSEMBLY CONTROL M9-500
2	1	1350110-04	DUST CAP ASSY W/CHAIN (MALE18D)
3	1	1351109-01	COUPLING Q/D MALE GAS FOR 1/4 TUBING ASSY
4	1	G1501N186A3A	CONN BACKSHELL
5	1	MS3106E18-1PF42	CONN 10 PIN STRAIGHT PLUG W/OUT ENDBELL
6	1	MS39056-3	CONN TELESCOPING BUSHING
7	1	AS200718	SPRING GUARD .34OD 18.00 LG
8	1	CWT11943	CABLE 09/22GA SHLD 0.270 OD 4TP+1 WHT-POLYUR JCKT 710023
9	1	CWT11..	CABLE 09/22GA SHLD 0.270 OD 4TP+1 WHT POLYUR JCKT 710023
10	1	261-PG-04	NUT/SLEEVE SPRING 1/4 TUBE
11	1	42060805-04	BOOT MALE GAS CLIP TYPE QD
12	1	44-P-YELLOW	TBG POLYETHYLENE YELLOW POLY-FLO 1/4 OD .040 WALL
13	1	44-P-YELLOW	TBG POLYETHYLENE YELLOW POLY-FLO 1/4 OD .040 WALL
14	1	7052	CONN 5 PIN FEMALE SUB-MINIATURE BLK W/GOLD PINS
15	1	34119	TERM RING 16-14 #4
16	1	2PF1	FTG 1/4-28 FEMALE
17	1	JF2P2SCD	CONN 4 PIN PLUG MINIATURE (GRY A,B-SKTS C,D-PINS
18	2	RC-150-2-BLK	CONDUIT FLEX .60 ID .79 OD BLK
19	1	A100865-1	CONN CONTACT BR FEM
20	1	A100864-1	CONN CONTACT BRASS MALE
21	2	B3407H	TERM RING #10 16-12 AWG
22	1	A100869-7	CONN CAM-LOK INSUL MALE PLUG BLK NO8-NO4 600V 150A
23	1	A100868-7	CONN CAM-LOK INSUL FEMALE BLK NO8-NO4 600V 150A
24	1	AS105-4-BLK	CABLE WELD 10AWG SILICONE GND
25	2	CU_006TX,62W	SLEEVE COPPER
26	1	AS105-4-RED(2)	CABLE WELD 10AWG SILICONE ELEC
27	1	AS105-4-BLK(2)	CABLE WELD 10AWG SILICONE GND
28	1	AS105-4-RED	CABLE WELD 10AWG SILICONE ELEC
29	2	FP-301-1,00	TUBING SHRINK

MODEL 9 - 500
IPB 090816
CABLE ASSEMBLY

ISSUED: 17 DEC 2002
REVISED:

FOR REFERENCE ONLY

**MODEL 9-500 CASSETTE CONVERSION
INSTRUCTIONS**

DWG#750026
ISSUED: 20 OCT 1989
REVISED: 4 MAY 1990

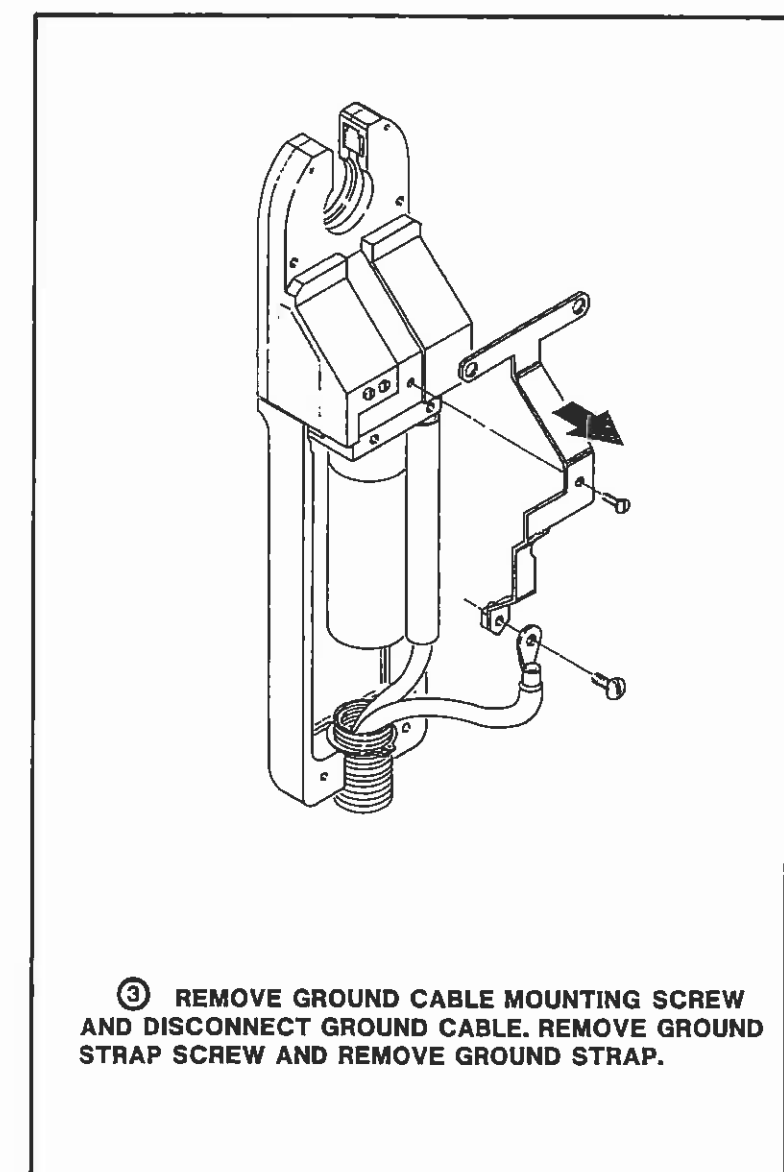
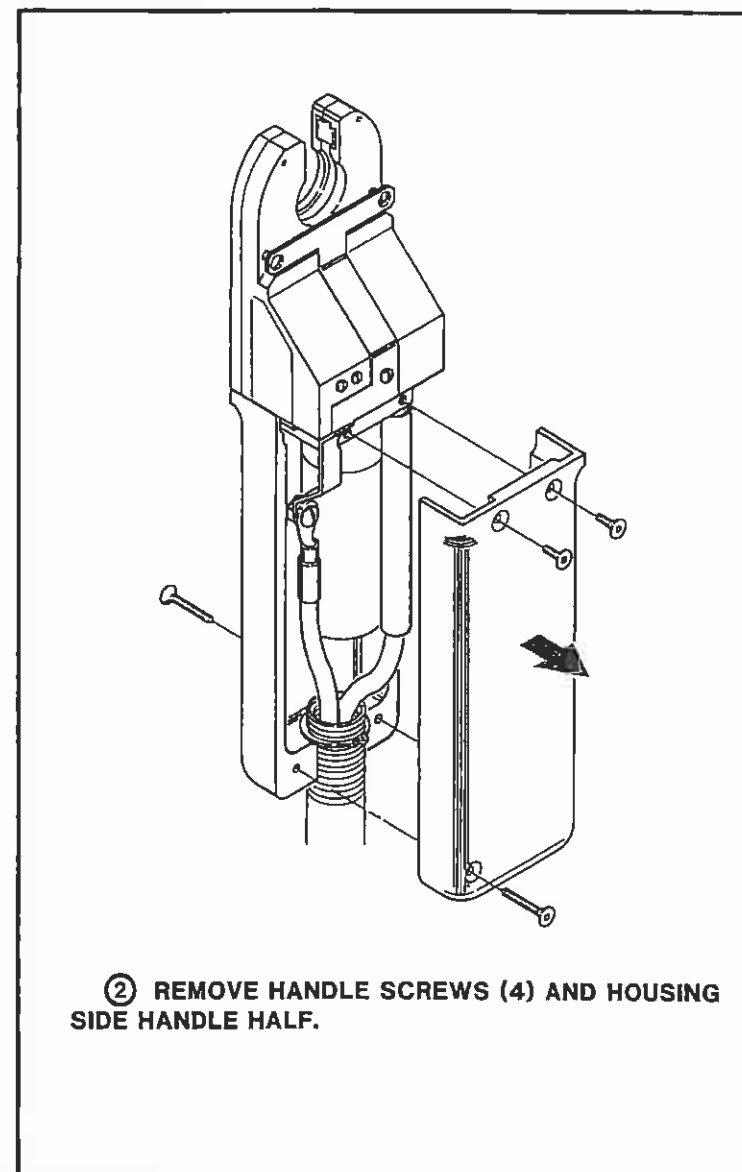
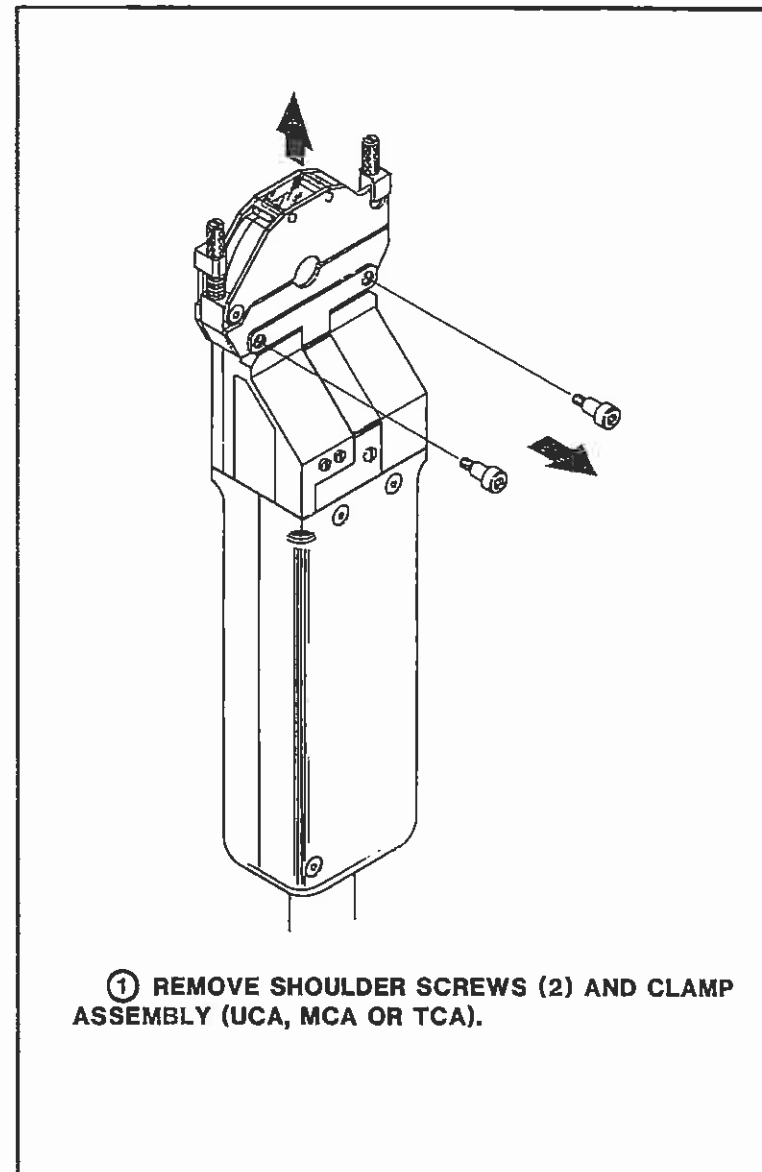

FOR REFERENCE ONLY

MODEL 9-500 CASSETTE CONVERSION INSTRUCTIONS

DWG#750026
ISSUED: 20 OCT 1989
REVISED: 4 MAY 1990

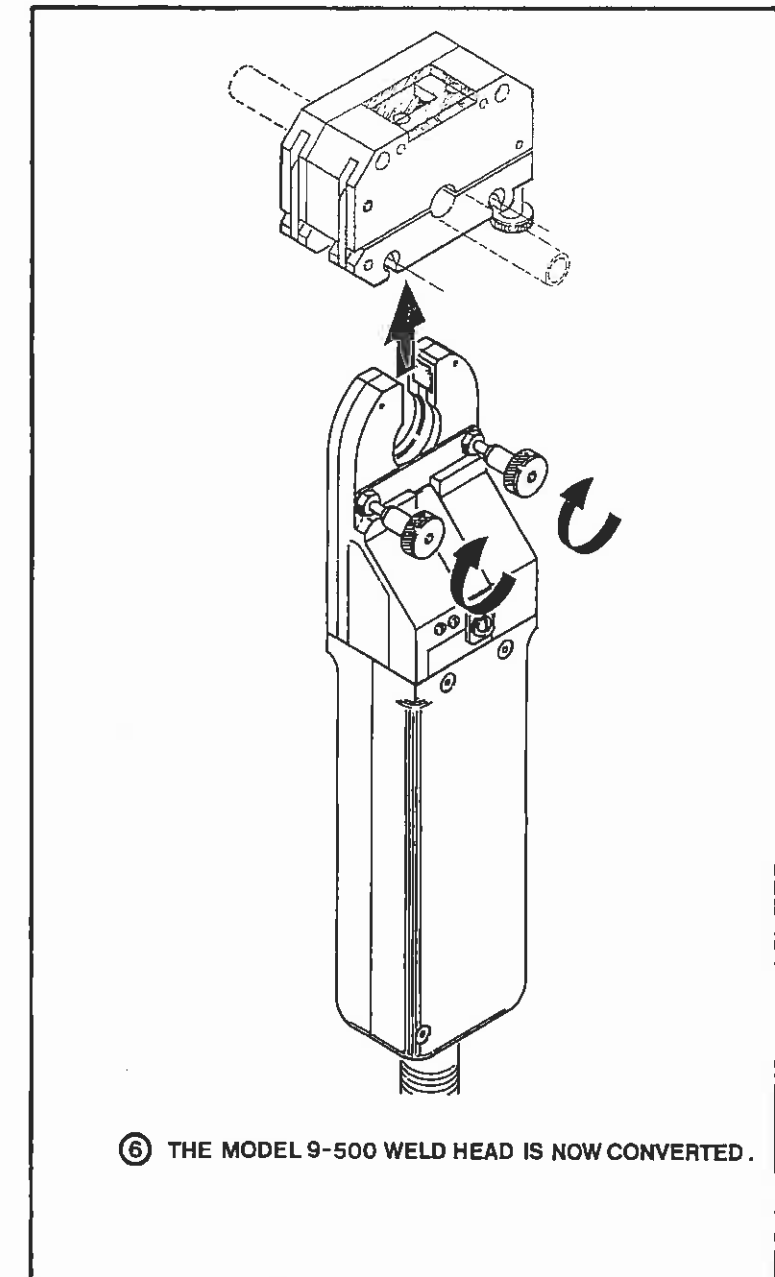
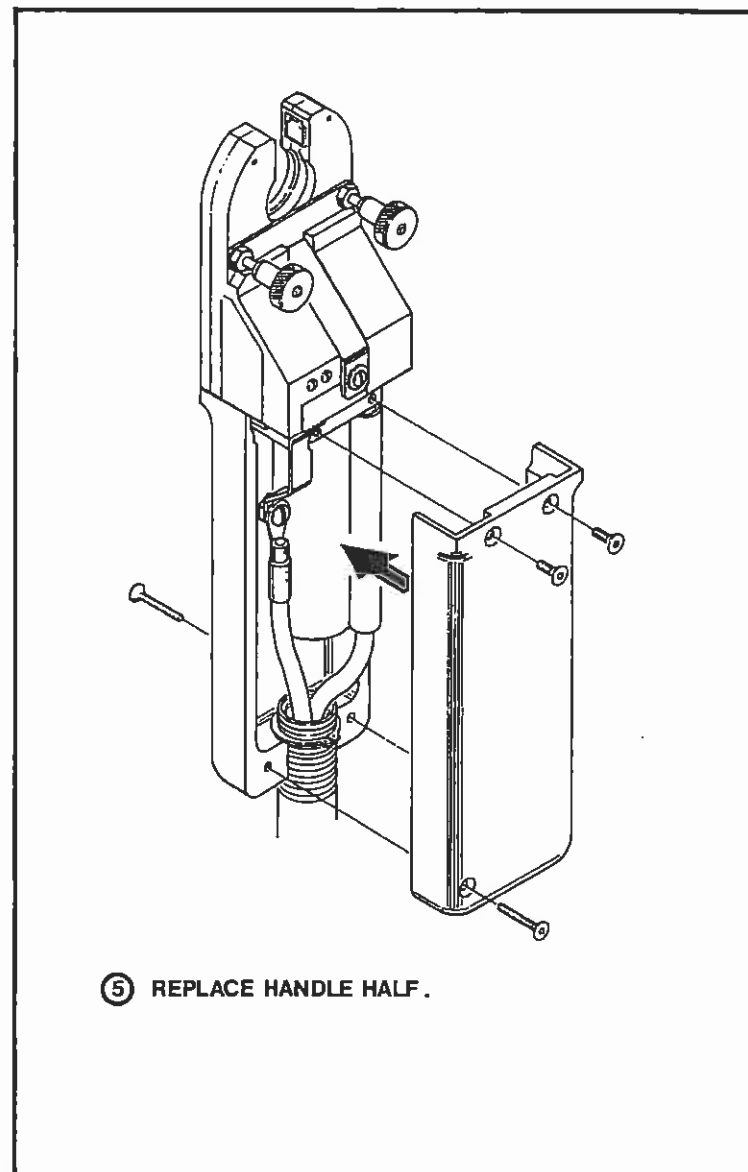
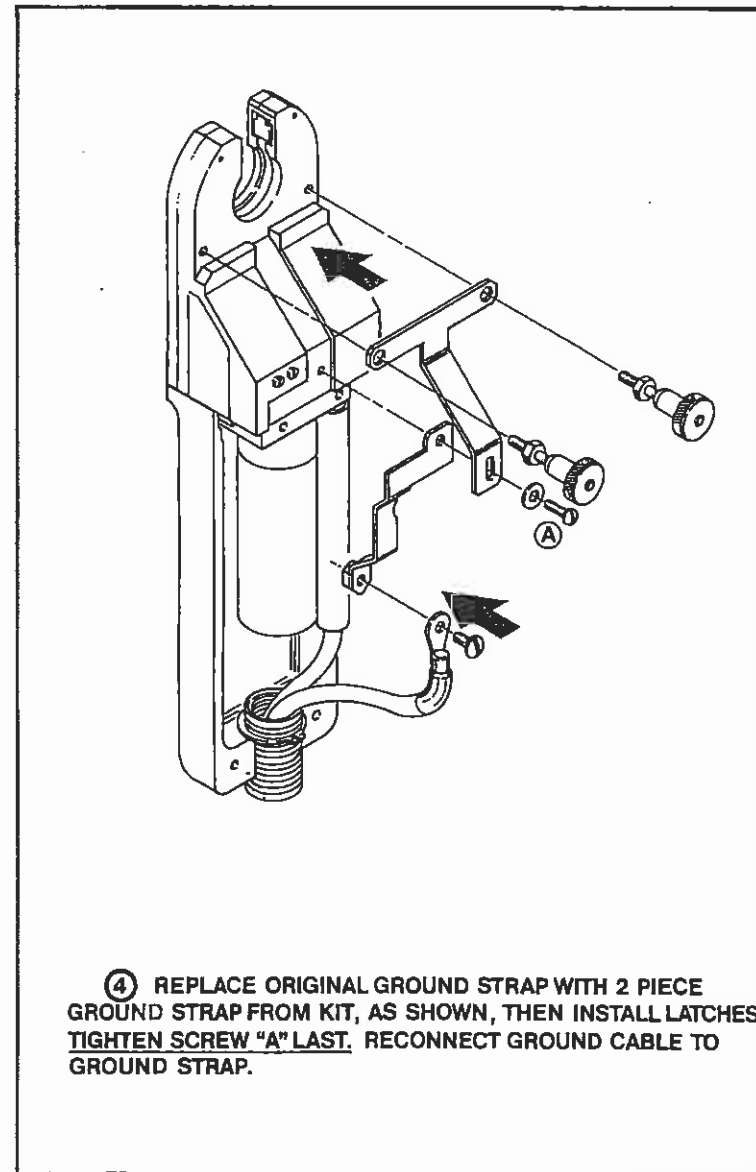

LTR	DCO	REVISIONS	DATE	BY	APPR
A	1438	REMOVE OLD MOTOR DIAGRAM	5-10-91	JRM	GPE
B	1716	C & D ON PJ-10 REVISED	11-24-92	MH	W
C		ADD M9-250 TO USED ON LIST	10-5-93	LEC	GPE
D	2947	ADDED PIOA & JIOA. REMOVED PN'S FOR PIDA, JIOA, P4	12-4-97	MC	GPE

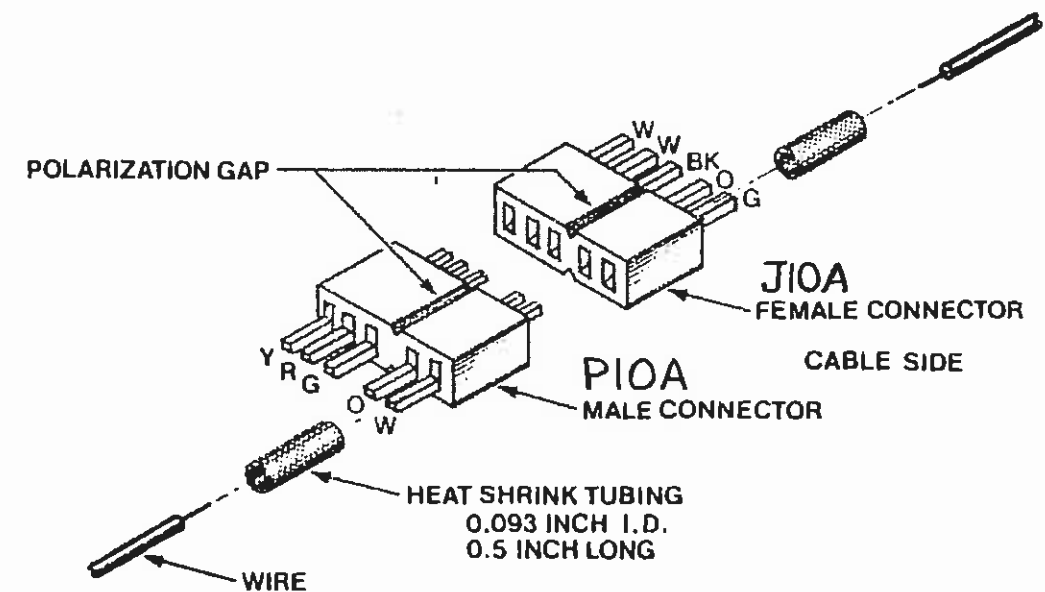
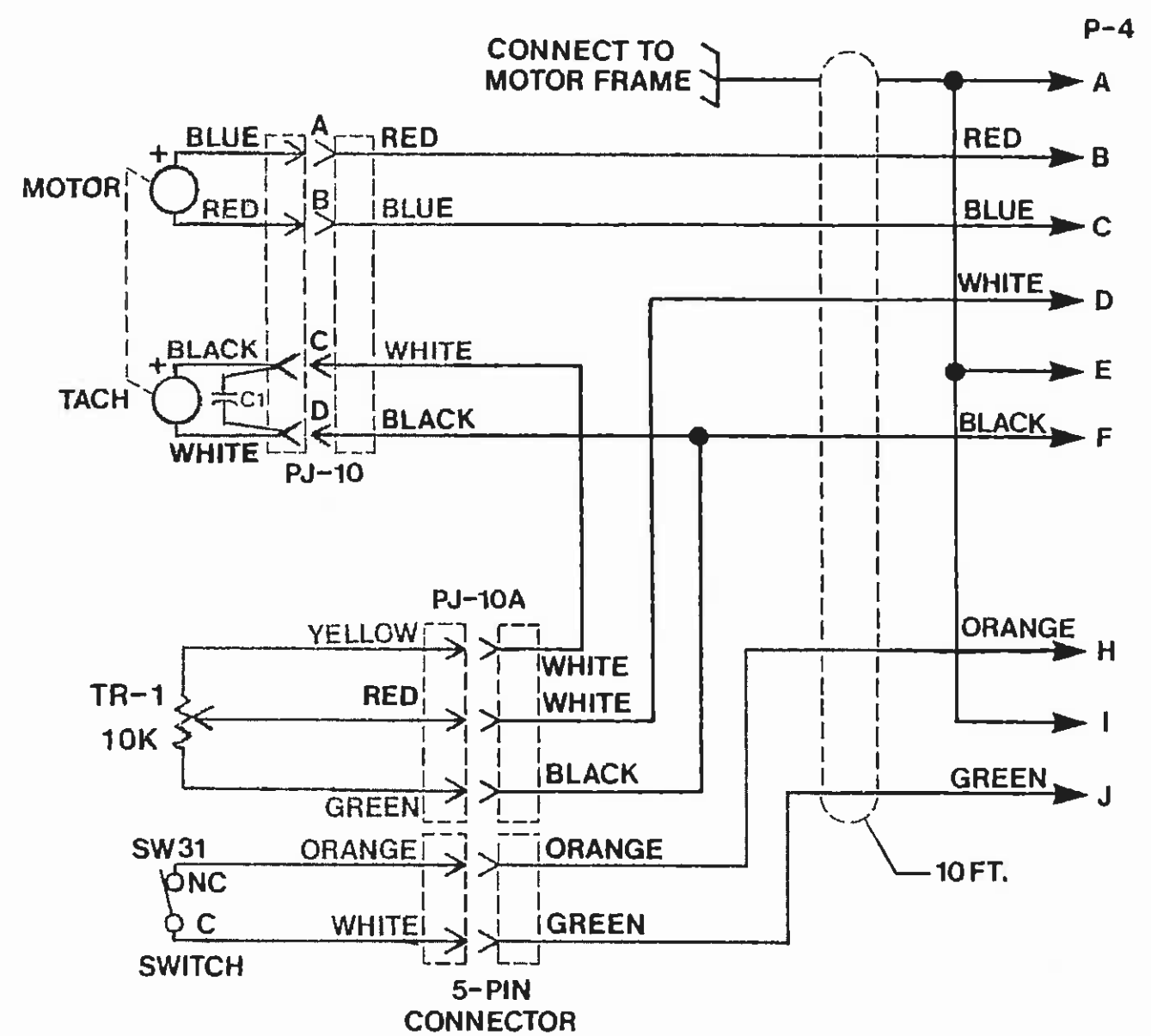

ITEM	QTY	IDENTIFYING NO	NOMENCLATURE OR DESCRIPTION	MFR	PART NO
PARTS LIST					
THIS DOCUMENT OR DRAWING AND THE INFORMATION CONTAINED HEREIN IS THE PROPERTY OF ARC MACHINES, INC., IS PROPRIETARY, IS SUBMITTED AND RECEIVED IN CONFIDENCE, SHALL BE USED ONLY FOR THE PURPOSE FOR WHICH IT IS SUBMITTED AND SHALL NOT BE COPIED IN WHOLE OR IN PART WITHOUT THE PRIOR EXPRESS WRITTEN PERMISSION OF ARC MACHINES, INC.					
UNLESS OTHERWISE SPECIFIED ALL DIMENSIONS ARE IN INCHES TOLERANCES ARE FRACTIONS DECIMALS ANGLES = 1/16 .001 = .002 = .005 =			THIRD ANGLE PROJECTION 	FOR IMPLIED STANDARDS SEE DOU-STD-100	
ALL MACHINED SURFACES TO BE			APPROVALS R. BILEK	DATE 10-16-85	
MATERIAL			J. McDonald	6-18-87	
REVISIONS USED ON			GPE	16-18-87	
APPROVALS			J. McDonald		
DESCRIPTION			ARC MACHINES INC.		
DESCRIPTION			MODEL 9 WELD HEAD WIRING DIAGRAM		
SIZE	MODEL NO	DRWG NO	REV		
A		175144-06	D		
DO NOT SCALE DRAWING			SHEET 1 OF 1		

FOR REFERENCE ONLY