

MODEL 9-4500 IPB Notice and Revision History



This document and the information contained herein is the property of Arc Machines, Inc. It is proprietary and submitted and received in confidence. It shall be used only for the purpose for which it is submitted and shall not be copied in whole or in part without the prior express written permission of Arc Machines, Inc. The information in this document has been carefully reviewed and is believed to be accurate. However, no responsibility is assumed for inaccuracies. Information and part numbers in this document are subject to change and Arc Machines, Inc. reserves the right to change required data without notice.



WARNING

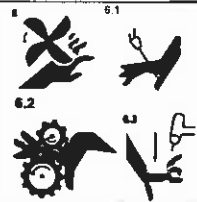

The nature of the GTAW process creates some POTENTIAL HAZARDS. In accordance with international safety regulations the EXCLAMATION SYMBOL indicates that this equipment is considered HAZARDOUS. The LIGHTNING FLASH SYMBOL indicates that there are potential electrical hazards. The display of these symbols makes it the OPERATOR'S RESPONSIBILITY TO ENSURE THAT THEY HAVE BEEN MADE AWARE OF and shall observe the hazardous conditions.

	WARNING: AMI factory training is essential for all Maintenance Technicians who operate AMI equipment. Do not operate or service this equipment without proper AMI approved training.
	WARNING: Keep hands and fingers clear from moving parts such as fans, gears, rotors, Wire Feed, Weld Head Travel, i.e. Oscillation (OSC) and Arc Voltage Control (AVC) mechanisms Weld Head AVC and Oscillator Slide Assemblies develop high forces and it is possible, by their nature of operation, to harm any object or body part that may get into these areas. USE EXTREME CAUTION!
	Electrical Shock Hazard: Always disconnect weld heads when servicing internal components or opening housing covers for access.

All rights reserved.

Publication date: First Edition – June 5, 2007

Copyright 2007 by Arc Machines, Inc.

REV	ECO #	CHANGE DESCRIPTION	DATE	BY	APR
A	4678	On 090119 Change Item 6 & 23	7 Mar 2008	SO	BF
B	4779	Added rev D of 750015	26 May 2008	SO	BF
C	5579	Added rev F 750015 and wiring diagram	18 Jan 2010	CB	DC
D	5753	Deleted pg 4 of 8 from IPB 090119, removed all cable parts from 090119, updated TOC	10/6/10	GB	DC

To be used for reference only

Property of Arc Machines, Inc.

TABLE OF CONTENTS

DATE EFFECTIVE: 26 April 1993

PRODUCT MODEL: 9-4500
MANUAL NUMBER: 730030

IPB NUMBER	DESCRIPTION
750015	MODEL 9 ELECTRODE DIMENSIONS
090119	MAIN ASSEMBLY
090516	LOCATING ARM KIT
090105	MODEL 9E CONFIGURATION
750031	MODEL 9 CONVERSION TO MODEL 9E INSTRUCTIONS
090800	CABLE ASSEMBLY M9
175144-04	MODEL 9 WELD HEAD WIRING DIAGRAM

To be used for reference only

ELECTRODE DIMENSIONS

ROTOR DIAMETER	
MODEL NO.	ROTOR O.D.
9-250	0.802
9-500/4-500	1.388
9-675	1.715
9M-750	1.312
9-750	2.000
9-1500	3.187
9AF-1500	2.252
9E-1500	2.687
8-2000	3.450
9-2500	4.380
9AF-2500	3.156
9E-2500	4.280
* 9-3500	5.380
9E-3500	5.310
8-4000	5.310
* 9-4500	6.875
9ER-4500	5.776
8-6625	8.094
* 9-7500	10.440
9E-7500	9.375
* FOR HEADS USING OPTIONAL TUNGSTEN EXTENDER, SEE PAGE 2.	

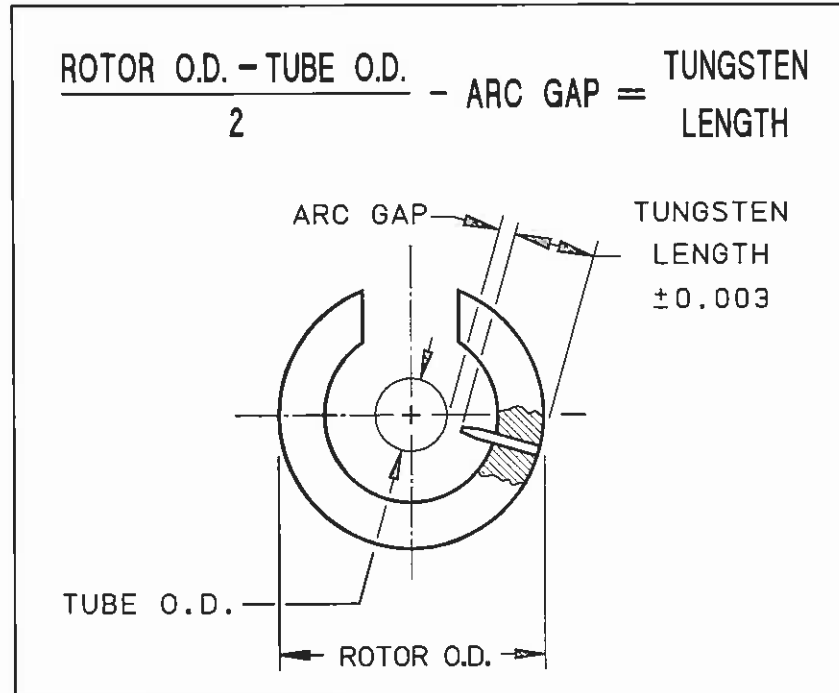

TUBE/PIPE WALL THICKNESS	RECOMMENDED ARC GAP	RECOMMENDED TIP DIA.
0.020/0.035	0.030	0.020
0.049/0.085	0.050	0.030
0.091/0.154	0.070	0.040

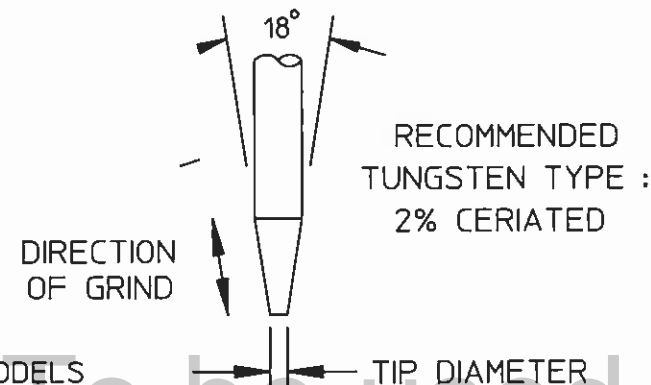

- NOTES:
1. RECOMMENDED ARC GAP FOR MODELS 4-500, 9-250 & 9-500 IS 0.045 MAXIMUM.
 2. IN INSTANCES WHERE OUT-OF-ROUNDNESS ON THIN-WALLED TUBING OCCURS (NORMALLY 2.500 O.D. OR LARGER), A 0.070 ARC GAP IS RECOMMENDED.
 3. DIMENSIONS ARE IN INCHES.

TUNGSTEN LENGTH CALCULATION FOR TUNGSTEN EXTENDERS

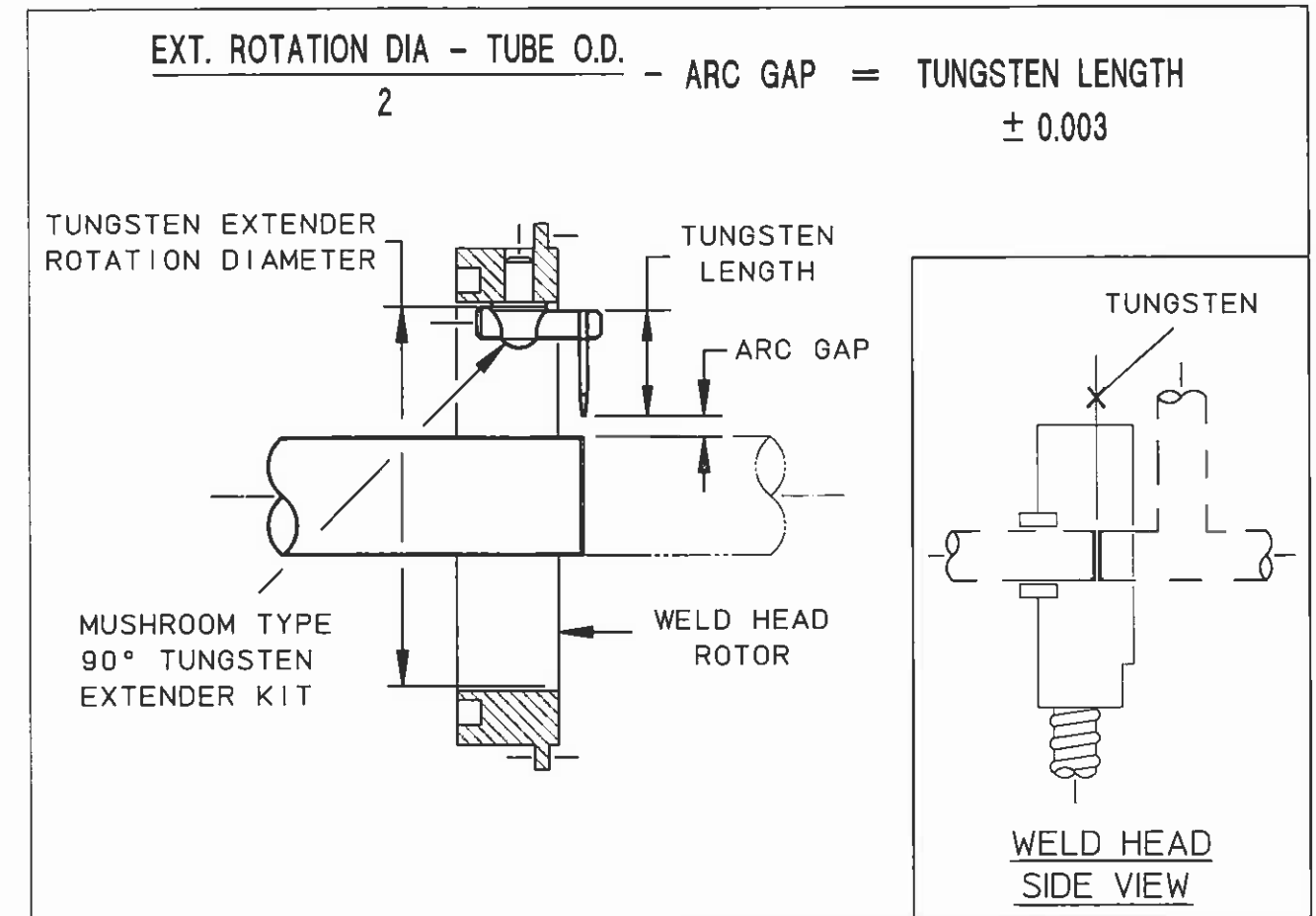

WELD HEAD MODEL NO.	KIT WITH 1/16 TUNGSTEN HOLDER PART NO.	KIT WITH 3/32 TUNGSTEN HOLDER PART NO.	TUNGSTEN EXTENDER ROTATION DIA.
9-1500	13090796-01	13090796-02	2.031
9-2500	13090796-05	13090796-06	3.156
9-3500	13090796-05	13090796-06	4.031
9-4500	13090796-03	13090796-04	4.920
9-7500	13090796-05	13090796-06	8.280

NOTES:

1. PART NUMBERS SHOWN ARE FOR REFERENCE ONLY AND ARE SUBJECT TO CHANGE.
2. CONTACT AMI SALES OR SERVICES FOR SPECIFIC PART NUMBER.

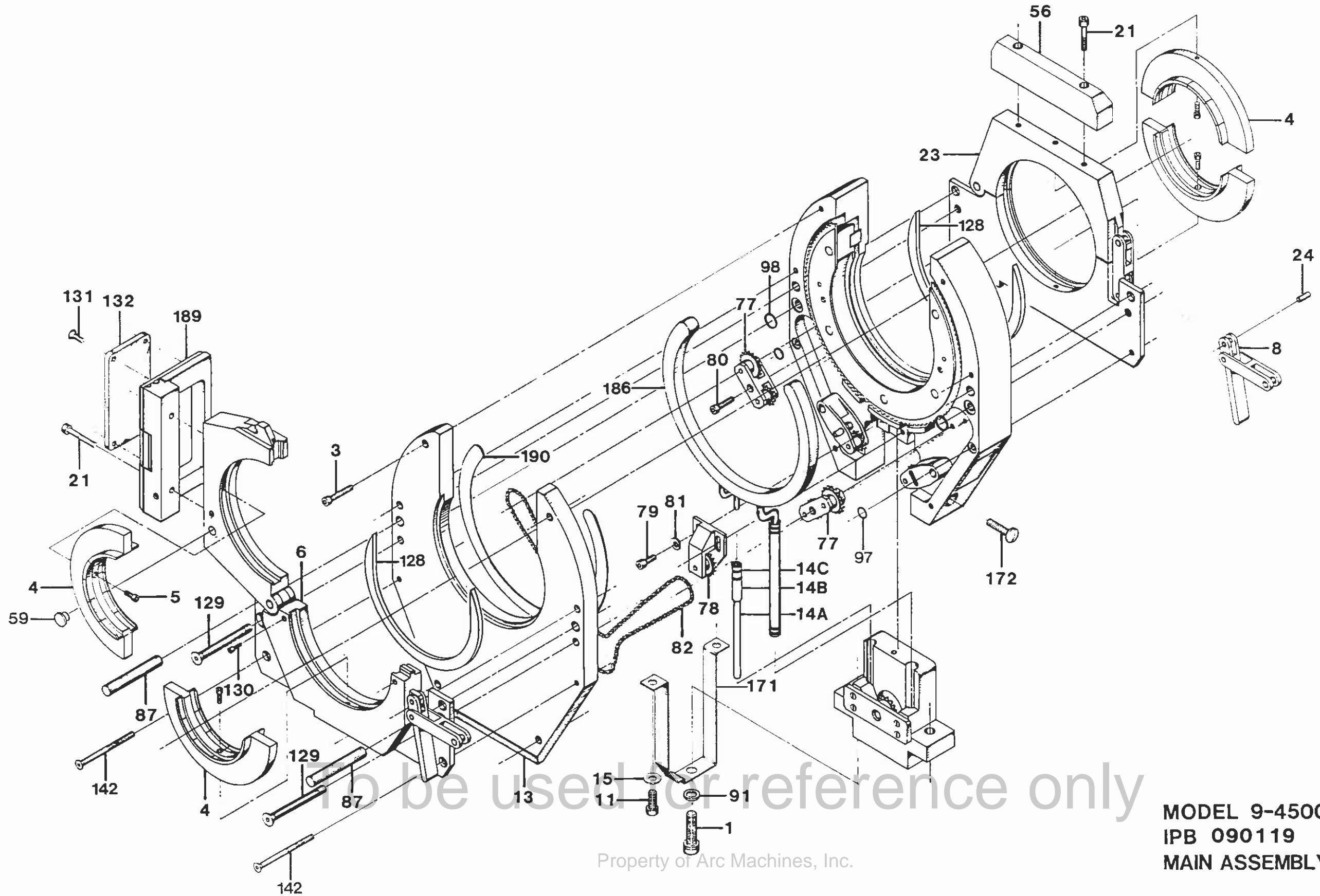

to be used for reference only

Property of Arc Machines, Inc.

MODEL 9-4500
IPB 090119
MAIN ASSEMBLY

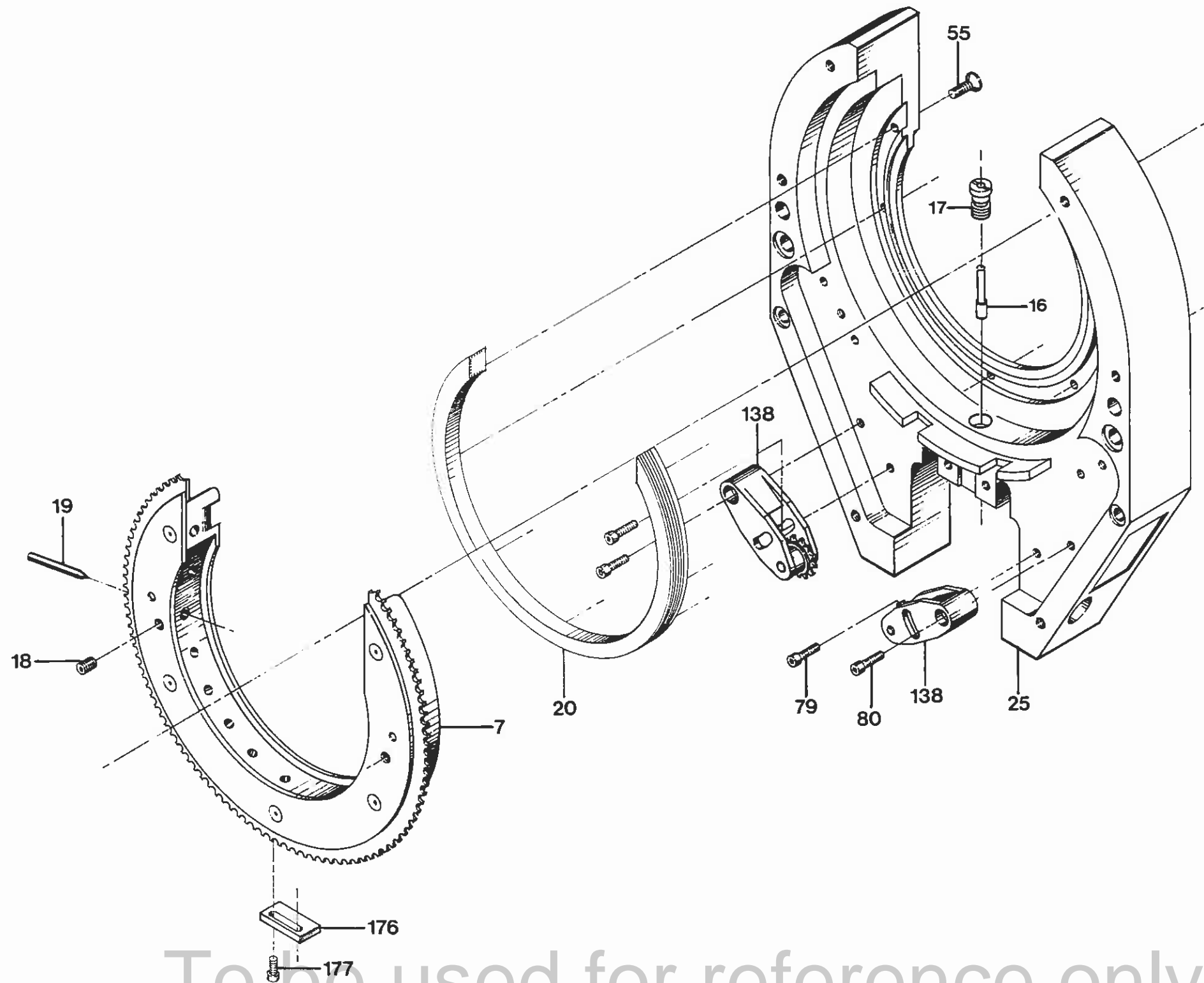

To be used for reference only

Property of Arc Machines, Inc.

MODEL 9-4500
IPB 090119
HOUSING ASSEMBLY

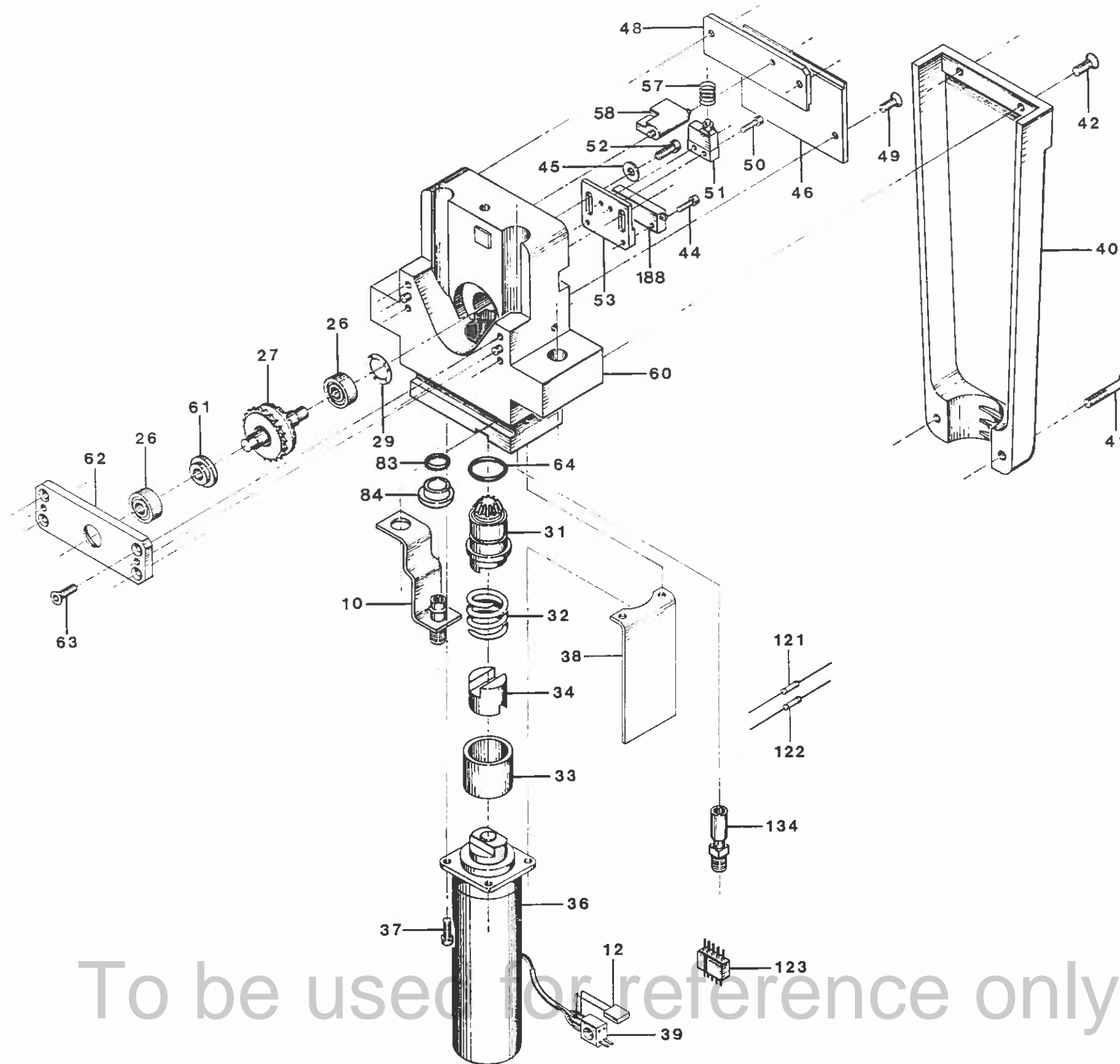

To be used for reference only

Property of Arc Machines, Inc.

MODEL 9-4500
IPB 090119
DRIVE ASSEMBLY

IPB NUMBER: 090119

TO ORDER
USE PART NUMBER
DO NOT USE IPB
ITEM NUMBER

ARC MACHINES, INC.

PRODUCT MODEL: 9-4500
DESCRIPTION: MAIN ASSEMBLY
MANUAL NUMBER: 730030
NOTES:

IPB ITEM NUMBER	QTY	U/M	PART NUMBER	DESCRIPTION	
1	2	EA	SCS31-18-1.25NP	SCREW CAP SKT 5/16-18 1-1/4 L	
2	0	-	-	-----	
3	4	EA	SCS08-32-0.87NP	SCREW CAP SKT 8-32 7/8 L	
4	0	-	-	-----	
5	4	EA	SCS06-32-0.37NP	SCREW CAP SKT 6-32 3/8 L	
6	1	EA	130905275-01	CLAMP HSG COVER SIDE 9-4500	ITEMS 8, 24, AND 59 INCLUDED
7	1	EA	13090790-01	ROTOR MOD 9-4500	ITEMS 18, 176, AND 177 INCLUDE
8	2	EA	13090577-01	LATCH ASSY M9-4500 M9E-4500	
10	1	EA	13090723-01	GROUND STRAP	
11	2	EA	SCS25-20-0.62SP	SCREW CAP SKT 1/4-20 5/8 L SP	
12	1	EA	CK06BX104K	CAP 0.1MF 100V 10%	
13	1	EA	42090145-01	HOUSING COVER MAIN	
14A	0.5	FT	029173	TBG SILICONE 1/8ID 1/4OD RED	
14B	0.08	FT	FP-301-0.25	TBG SHRINK	
14C	18	IN	MS20995C25	LOCKWIRE 1LB SPOOL .025D 304SS	
15	2	EA	W25NP-FL	WASHER FL 1/4	
16	1	EA	42091108-02	PIN ACT	
17	1	EA	42091108-01	BUSHING HOUSING UPPER M9-4500	
18	2	EA	SSS06-32-18NPCU	SCREW SET SKT 6-32 3/16 L CUPT	
19	0	-	-	-----	
20	1	EA	42090746-02	GUIDE RING	
21	4	EA	SCS10-32-1.25NP	SCREW CAP SKT 10-32 1-1/4 L	
22	0	EA	-	-----	
23	1	EA	130905274-01	CLAMP HSG HSG SIDE 9-4500	ITEMS 8 AND 24 INCLUDED
24	2	EA	PD18-0.37SS	PIN DOWEL 3/16D 3/8L SST	
25	1	EA	42090144-01	HOUSING UPPER	
26	2	EA	SSR-3LLRA3P2 [BEARING BALL .18 .50 [5LY-101]	
27	1	EA	13090613-01	GEAR BEVEL	
28	0	-	-	-----	
29	1	EA	SV-8	SPRING WAVE WASHER .351D .44	
30	0	-	-	-----	
31	1	EA	13090602-07	GEAR PINION DRIVE	
32	1	EA	15156	SPRING CPRSN .81D .70L .067W	
33	1	EA	42090602-04	SPACER SPRING	
34	1	EA	42090602-03	COUPLING INSULATING DELRIN	
35	1	EA	13090800-01	CABLE M9 10 FT	
36	1	EA	13090602-03	MOTOR DRIVE PINION 81 RPM	ITEMS 12 AND 39 INCLUDED

To be used for reference only

PRICE, PART NUMBER AND
DESCRIPTION SUBJECT TO
CHANGE WITHOUT NOTICE

IPB NUMBER: 090119

TO ORDER
USE PART NUMBER
DO NOT USE IPB
ITEM NUMBER

ARC MACHINES, INC.
PRODUCT MODEL: 9-4500
DESCRIPTION: MAIN ASSEMBLY
MANUAL NUMBER: 730030
NOTES:

IPB ITEM NUMBER	QTY	U/M	PART NUMBER	DESCRIPTION
37	4	EA	SCS04-40-0.31NP	SCREW CAP SKT 4-40 5/16 L
38	1	EA	42091102-04	INSULATOR SKIRT
39	1	EA	JF2P2SCD	CONN 4 PIN PLUG MINIATURE
40	2	EA	42090104-01	HANDLE
41	2	EA	SFS04-40-1.00NP	SCREW FLH SKT 4-40 1.00 L
42	4	EA	SFS04-40-0.37NP	SCREW FLH SKT 4-40 3/8 L
43	0	-	-	-----
44	2	EA	SCS02-56-0.25NP	SCREW CAP SKT 2-56 1/4 L
45	2	EA	W04-FL	WASHER FLAT #4
46	1	EA	42090619-02	COVER PLATE BOT LIMIT SW
47	0	-	-	-----
48	1	EA	42090619-01	COVER PLATE TOP LIMIT SW
49	4	EA	SFS04-40-0.31NP	SCREW FLH SKT 4-40 5/16 L
50	2	EA	SCS02-56-0.25NP	SCREW CAP SKT 2-56 1/4 L
51	1	EA	MMGGD1D0C	SWITCH LIMIT PLUNGER
52	2	EA	SCS04-40-0.25NP	SCREW CAP SKT 4-40 1/4 L
53	1	EA	42090616-05	PLATE LIMIT SWITCH
54	0	-	-	-----
55	7	EA	SFL08-32-0.62NY	SCREW FLH SLT 8-32 5/8 L NYL
56	1	EA	42090585-02	CLOSURE 9-4500
57	1	EA	L-14	SPRING CPRSN .25D .43L .020W
58	1	EA	42091108-03	LEVER LIMIT SW ACTR
59	1	EA	651	PLUG 5/16 DIA HOLE
60	1	EA	42090146-01	HOUSING DRIVE
61	1	EA	42090617-02	SPACER BEVEL GEAR
62	1	EA	42090548-02	RETAINER PLATE
63	4	EA	SFS04-40-0.37NP	SCREW FLH SKT 4-40 3/8 L
64	1	EA	2-014	O RING .489 ID .070 W
65	1	EA	JF2S2PCD	CONN 4 SOCKET RECEPTACLE MINTR
66	0	-	-	-----
67	0	-	-	-----
77	2	EA	13090625-01	BRACKET H R/H
78	1	EA	13090626-01	BRACKET TENSIONER
79	4	EA	SCS08-32-0.37NP	SCREW CAP SKT 8-32 3/8 L
80	4	EA	SCS08-32-0.75NP	SCREW CAP SKT 8-32 3/4 L
81	2	EA	W08NP-FL	WASHER FLAT #8
82	1	EA	RC14SS-177	OBS USE P/N 47SS-177

To be used for reference only

PRICE, PART NUMBER AND
DESCRIPTION SUBJECT TO
CHANGE WITHOUT NOTICE

IPB NUMBER: 090119

TO ORDER
USE PART NUMBER
DO NOT USE IPB
ITEM NUMBER

ARC MACHINES, INC.
PRODUCT MODEL: 9-4500
DESCRIPTION: MAIN ASSEMBLY
MANUAL NUMBER: 730030
NOTES:

IPB ITEM NUMBER	QTY	U/M	PART NUMBER	DESCRIPTION
83	1	EA	2-010-S604-70	O RING .238 ID .070 W SILICONE
84	1	EA	420901126-02	GROMMET
87	2	EA	42090164-05	PIN .375D 2.45L 9-4500
88	0	-	-	-----
89	0	-	-	-----
91	2	EA	W31SS-FL	WASHER FL 5/16 SIZE SST
92	1	EA	42060800 02	COUPLING Q/D CONN (SM 251B)
93	1	EA	SM252B	COUPLING
94	1	EA	394 PMD 04	DO NOT SELL USE: 1351109-01
95	1	EA	MS3106E10 1P	CONN 10 PIN PLUG
96	1	EA	G1501N106A3A	CONN BACKSHELL
97	2	EA	2-106-S604-70	O RING .174 ID .103 W SILICONE
98	2	EA	2-108-S604-70	O RING .237 ID .103 W SILICONE
99	1	EA	MS39056-3	CONN TELESCOPIC BUSHING
105	0	-	-	-----
106	0	-	-	-----
107	0	-	-	-----
121	1	EA	RN55D1300F	RES 130 OHMS 1/4W
122	1	EA	RN55D7871F	RES 7.87K
123	1	EA	5PM	OBS USE 7051
124	1	EA	5PF	OBS USE 7052
125	0	-	-	-----
126	1	EA	2PF1	FTG 1/4-28 FEMALE
127	2	EA	42060800 01	OBS (USE ARC 1981)
128	2	EA	420907168-02	HEAT SHIELD 9-4500
129	2	EA	13090124-05	SCREW INSULATED UPPER
130	4	EA	SCS04-40-0.50NP	SCREW CAP SKT 4-40 1/2 L
131	4	EA	SFL06-32-0.50NY	SCREW FLH SLT 6-32 1/2 L NYL
132	1	EA	42090585-03	WINDOW 9-4500
134	1	EA	13090803-01	TUBE FTG GAS
135	1	EA	R6100206B	TERM 16 14 AWC #6
136	0	-	-	-----
138	2	EA	13090636-01	BRACKET TENSIONER
139	0	-	-	-----
140	0	-	-	-----
142	2	EA	13090124-04	SCREW INSULATED LOWER
143	0	-	-	-----

To be used for reference only

PRICE, PART NUMBER AND
DESCRIPTION SUBJECT TO
CHANGE WITHOUT NOTICE

IPB NUMBER: 090119

TO ORDER
USE PART NUMBER
DO NOT USE IPB
ITEM NUMBER

ARC MACHINES, INC.
PRODUCT MODEL: 9-4500
DESCRIPTION: MAIN ASSEMBLY
MANUAL NUMBER: 730030
NOTES:

IPB ITEM NUMBER	QTY	U/M	PART NUMBER	DESCRIPTION
144	1	EA	42060805 04	BOOT MALE GAS
145	2	EA	42060804 01	BOOT MALE POWER/GROUND
146	2	EA	42060800 07	FTG COUPLING HOSE/CABLE
147	0	-	-	-----
148	0	-	-	-----
171	1	EA	42090749-01	CONDUCTOR GND STRAP
172	1	EA	SPL25-20-0.50NY	SCREW PNH SLT 1/4-20 1/2 L NYL
173	0	-	-	-----
174	1	EA	261 PG 04	FTG NUT/SLEEVE SPRING 1/4 TUBE
175	1	EA	AS200718	SPRING GUARD .34 OD 18.00 LG
176	1	EA	42090548-05	CAM SWITCH
177	2	EA	SCS04-40-0.31NP	SCREW CAP SKT 4-40 5/16 L
185	1	EA	1350110 04	DUST CAP ASSY W/CHAIN(MALE18D)
186	1	EA	13090770-01	CONDUCTOR RING 9-4500
187	0	-	-	-----
188	1	EA	3057L-1-202	POT TRIM 2K OHM 5%
189	1	EA	130905214-04	CLOSURE FLIP-TOP 9-4500
190	1	EA	420907212-01	PLATE BACKING M9-4500
200	9	FT	DUCT 0.87 50 W	CONDUIT WHT 0.87 ID
201	6	IN	M23053/5 111 0	TBG SHRINK 1-1/2 ID BLK

To be used for reference only
PRICE, PART NUMBER AND
DESCRIPTION SUBJECT TO
CHANGE WITHOUT NOTICE

Page 8 of 8

Property of Arc Machines, Inc.

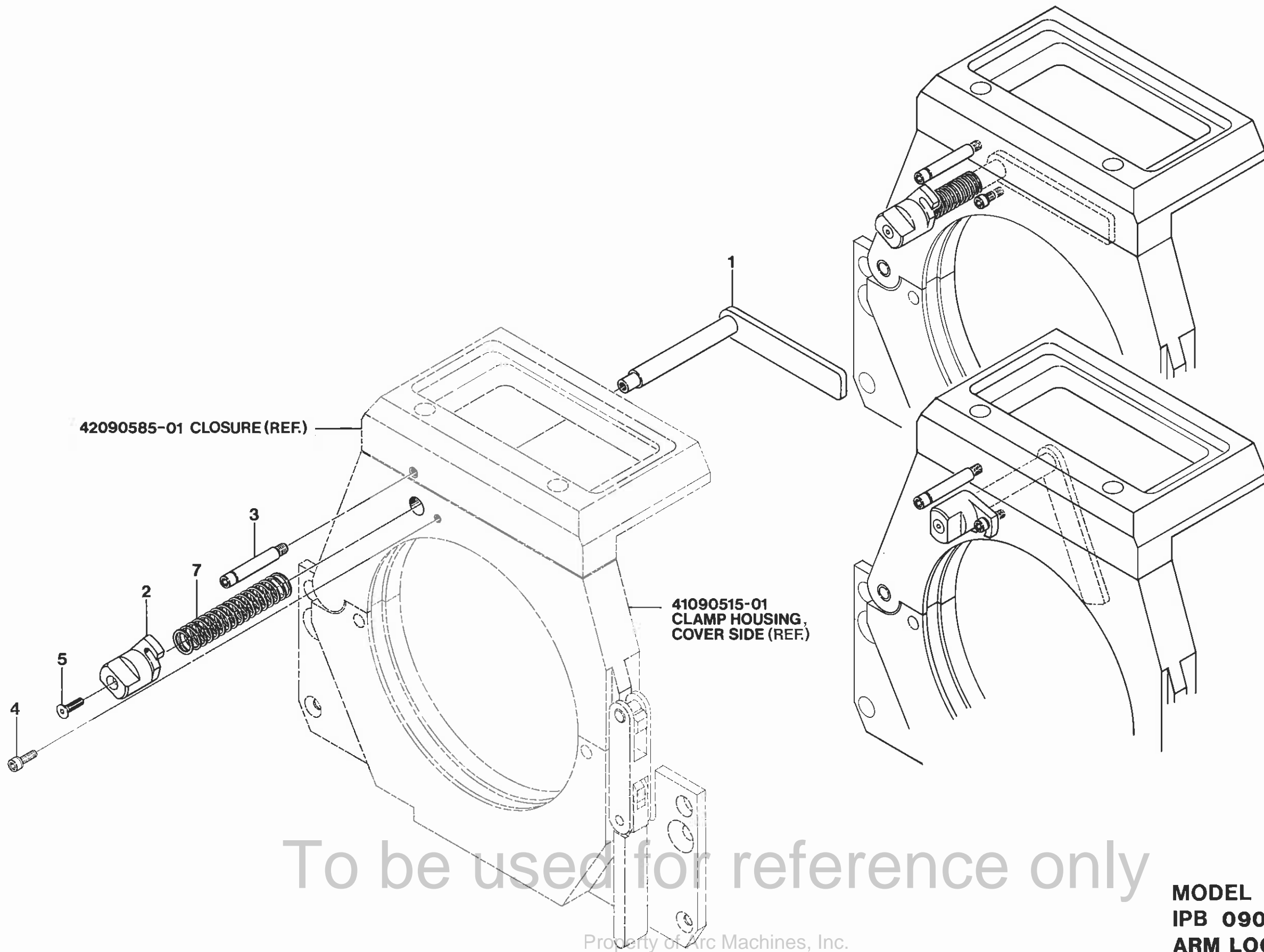

To be used for reference only

Property of Arc Machines, Inc.

MODEL 9-4500
IPB 090516
ARM LOCATING KIT

IPB NUMBER: 090516

TO ORDER
USE PART NUMBER
DO NOT USE IPB
ITEM NUMBER

ARC MACHINES, INC.

PRODUCT MODEL: 9-4500
DESCRIPTION: LOCATING ARM KIT
MANUAL NUMBER: 730030
NOTES:

IPB ITEM NUMBER	QTY	U/M	PART NUMBER	DESCRIPTION
1	1	EA	130905123-03	ARM LOCATING BRAZED
2	1	EA	130905108-01	KNOB ASSY 1500 2500 3500 4500
3	1	EA	420905277-05	STOP (44D23)
4	1	EA	SCS04-40-0.37NP	SCREW CAP SKT 4-40 3/8 L
5	1	EA	SFS02-56-0.31NP	SCREW FLH SKT 2-56 5/16 L
6	0	-	-	-----
7	1	EA	S-3048	SPRING CPRSN .36D 2.25L .029W

To be used for reference only

PRICE, PART NUMBER AND
DESCRIPTION SUBJECT TO
CHANGE WITHOUT NOTICE

Page 2 of 2

Property of Arc Machines, Inc.

THIS DOCUMENT OR DRAWING AND THE INFORMATION CONTAINED HEREIN IS THE PROPERTY OF ARC MACHINES, INC., IS PROPRIETARY, IS SUBMITTED AND RECEIVED IN CONFIDENCE, SHALL BE USED ONLY FOR THE PURPOSE FOR WHICH IT IS SUBMITTED AND SHALL NOT BE COPIED IN WHOLE OR IN PART WITHOUT THE PRIOR EXPRESS WRITTEN PERMISSION OF ARC MACHINES, INC.

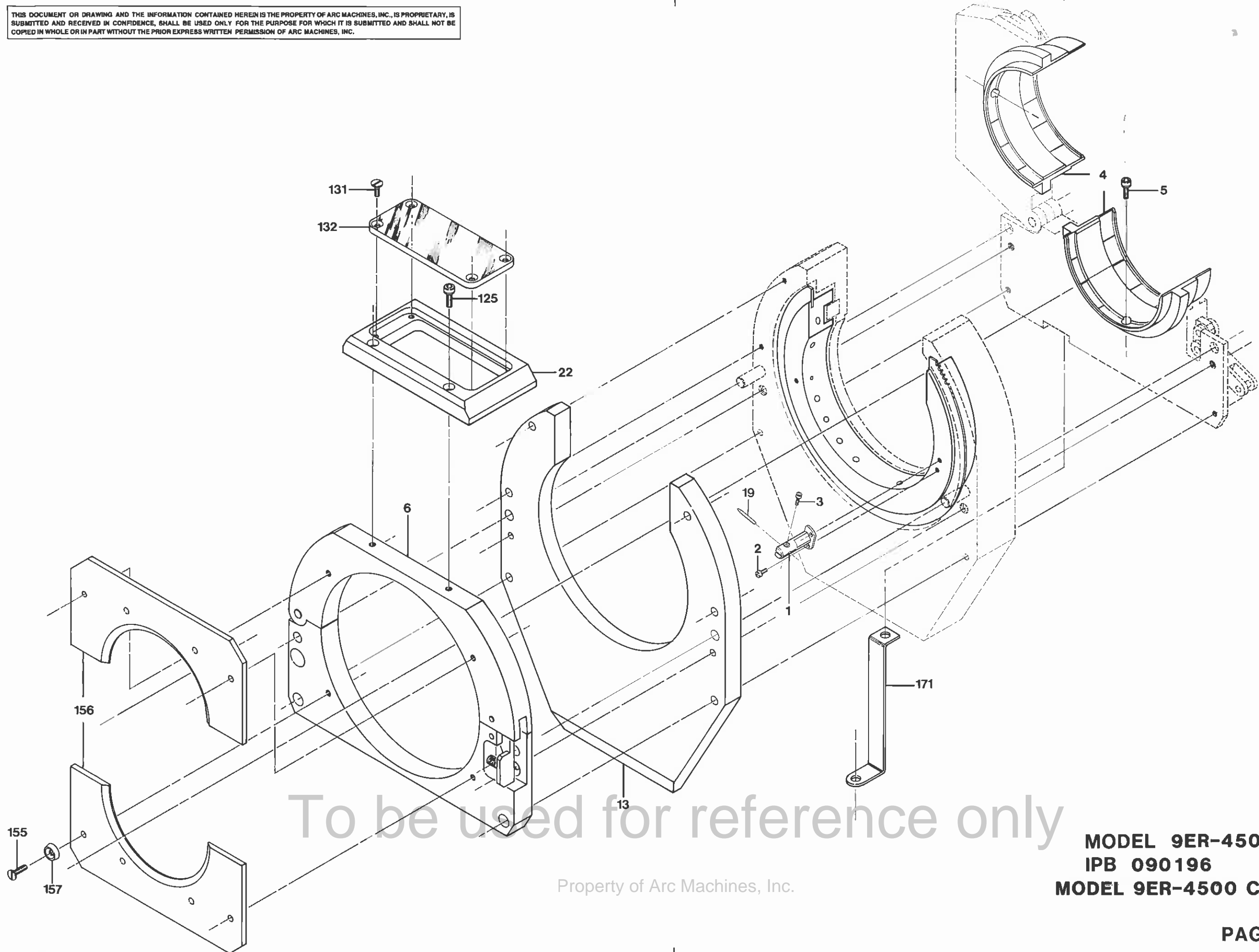

To be used for reference only

Property of Arc Machines, Inc.

MODEL 9ER-4500
IPB 090196
MODEL 9ER-4500 CONFIGURATION

IPB NUMBER: 090196

TO ORDER
USE PART NUMBER
DO NOT USE IPB
ITEM NUMBER

ARC MACHINES, INC.

PRODUCT MODEL: 9-4500
DESCRIPTION: MODEL 9ER-4500 COFIGURATION
MANUAL NUMBER: 730030
NOTES:

IPB ITEM NUMBER	QTY	U/M	PART NUMBER	DESCRIPTION	
1	1	EA	420907185-01	HOLDER ELECTRODE.094D 9ER-4500	
2	2	EA	SCS06-32-0.25NP	SCREW CAP SKT 6-32 1/4 L	
3	1	EA	SCS04-40-0.31NP	SCREW CAP SKT 4-40 5/16 L	
4	0	-	-	-----	WIDE CLAMP INSERT-ORD BY SIZE
5	2	EA	SCS06-32-0.37NP	SCREW CAP SKT 6-32 3/8 L	
6	1	EA	13090552-01	HOUSING GAS SEAL 9E-4500	
7	0	-	-	-----	
13	1	EA	420901115-01	COVER HOUSING MAIN 9ER-4500	
14	0	-	-	-----	
19	0	-	-	-----	TUNGSTEN
20	0	-	-	-----	
22	1	EA	420905194-01	CLOSURE 9E-4500	
23	0	-	-	-----	
125	2	EA	SCS10-32-0.75NP	SCREW CAP SKT 10-32 3/4 L	
126	0	-	-	-----	
131	4	EA	SFL06-32-0.31NY	SCREW FLH SLT 6-32 5/16 L NYL	
132	1	EA	42090585-03	WINDOW 9-4500	
133	0	-	-	-----	
155	4	EA	SFL08-32-0.50NY	SCREW FLH SLT 8-32 1/2 L NYL	
156	0	-	-	-----	GAS SEAL-ORD BY SIZE
157	1	EA	11SFW0008	WASHER NYLON FINISHING #8	
158	0	-	-	-----	
171	1	EA	42090749-04	GROUND STRAP	

To be used for reference only

PRICE, PART NUMBER AND
DESCRIPTION SUBJECT TO
CHANGE WITHOUT NOTICE

Page 2 of 2

Property of Arc Machines, Inc.

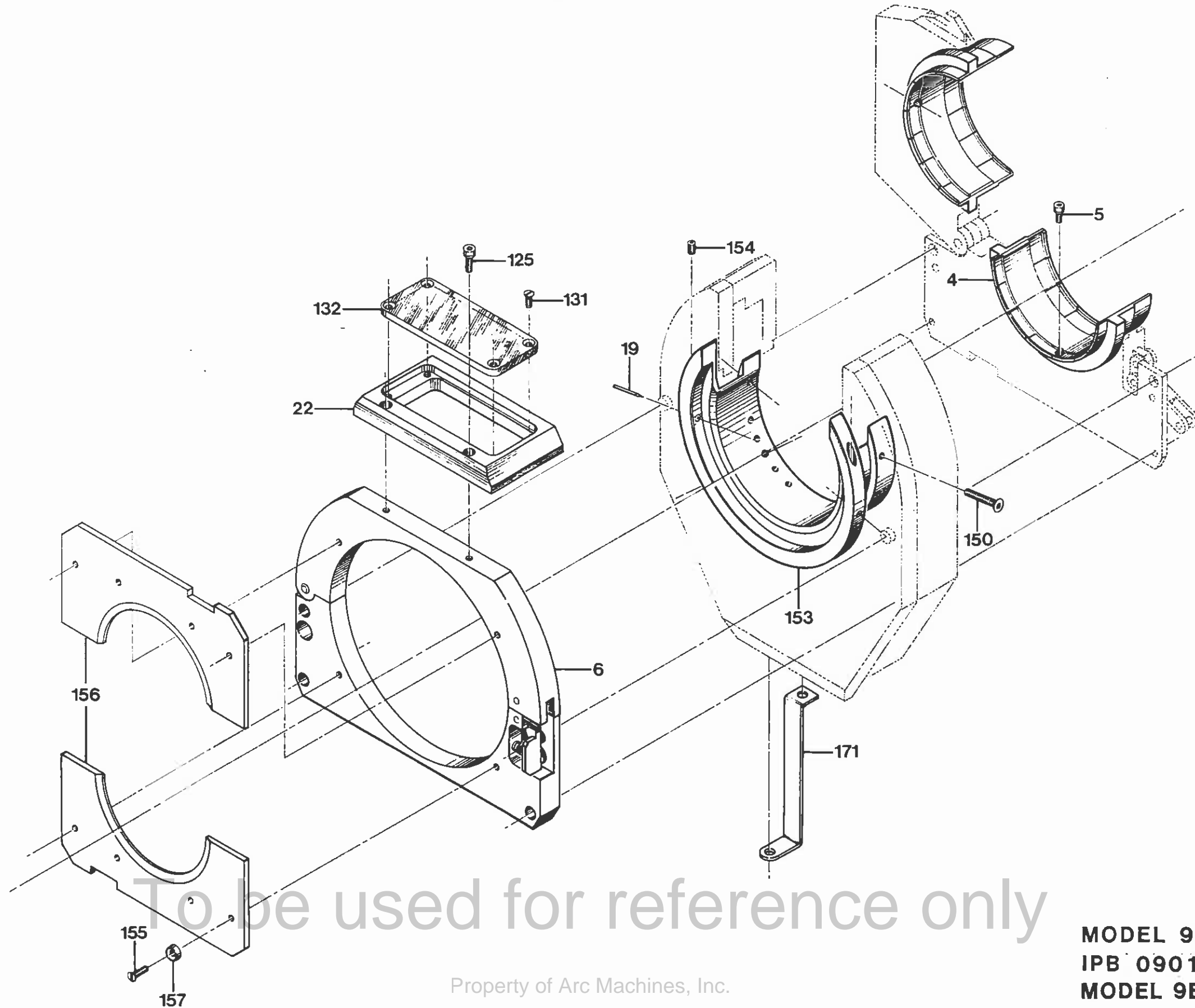

To be used for reference only

Property of Arc Machines, Inc.

MODEL 9E-4500
IPB 090105
MODEL 9E CONFIGURATION

IPB NUMBER: 090105

TO ORDER
USE PART NUMBER
DO NOT USE IPB
ITEM NUMBER

ARC MACHINES, INC.

PRODUCT MODEL: 9-4500
DESCRIPTION: MODEL 9E COFIGURATION
MANUAL NUMBER: 730030
NOTES:

IPB ITEM NUMBER	QTY	U/M	PART NUMBER	DESCRIPTION	
1	0	-	-	-----	
4	0	-	-	-----	CLAMP INSERT-ORD BY SIZE
5	2	EA	SCS06-32-0.37NP	SCREW CAP SKT 6-32 3/8 L	
6	1	EA	13090552-01	HOUSING GAS SEAL 9E-4500	
7	0	-	-	-----	
19	0	-	-	-----	
22	1	EA	420905194-01	CLOSURE 9E-4500	ITEMS 131 AND 132 INCLUDED
23	0	-	-	-----	
125	2	EA	SCS10-32-0.75NP	SCREW CAP SKT 10-32 3/4 L	
126	0	-	-	-----	
131	4	EA	SFL06-32-0.31NY	SCREW FLH SLT 6-32 5/16 L NYL	
132	1	EA	42090585-03	WINDOW 9-4500	
133	0	-	-	-----	
150	3	EA	SFS08-32-1.00NP	SCREW FLH SKT 8-32 1.00 L	
151	0	-	-	-----	
153	1	EA	13090739-01	ROTOR EXTENSION 9E-4500	
154	2	EA	420907144-12	SCREW SET SKT 6-32 3/8 L FLPT	
155	4	EA	SFL08-32-0.50NY	SCREW FLH SLT 8-32 1/2 L NYL	
156	0	-	-	-----	GAS SEAL-ORD BY SIZE
157	4	EA	11SFW0008	WASHER NYLON FINISHING #8	
158	0	-	-	-----	
171	1	EA	42090749-04	GROUND STRAP	
172	0	-	-	-----	
180	1	EA	13090158-04	KIT CVRSN M9-4500 TO M9E-4500	

To be used for reference only

PRICE, PART NUMBER AND
DESCRIPTION SUBJECT TO
CHANGE WITHOUT NOTICE

Page 2 of 2

Property of Arc Machines, Inc.

**MODEL 9 CONVERSION TO MODEL 9E
INSTRUCTIONS**

P/N 750031

(MODELS 9-1500, 9-2500, 9-3500, 9-4500 AND 9-7500)

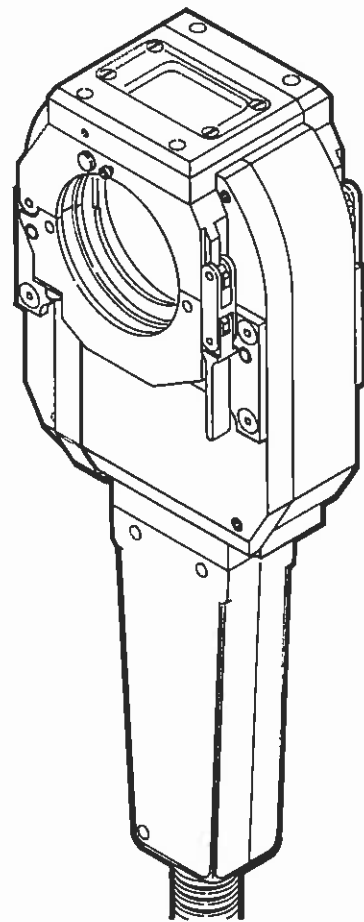

MODEL 9

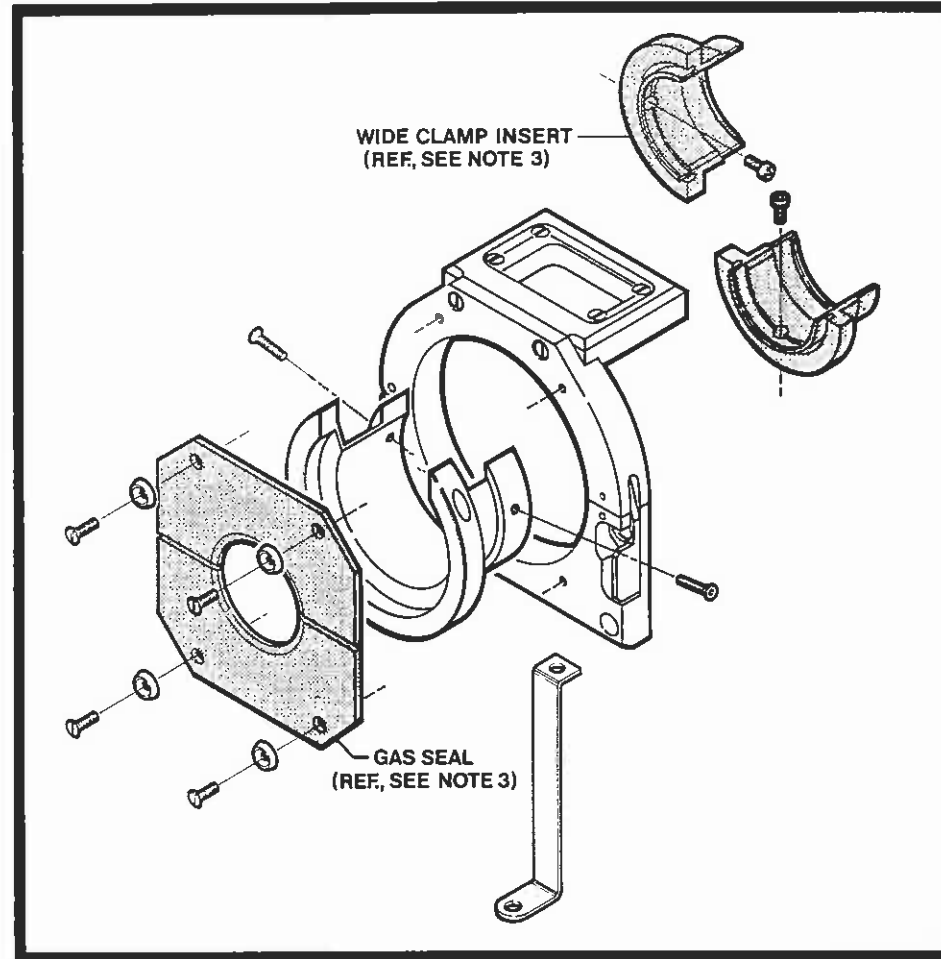

**MODEL 9E KIT
(OPTION)**

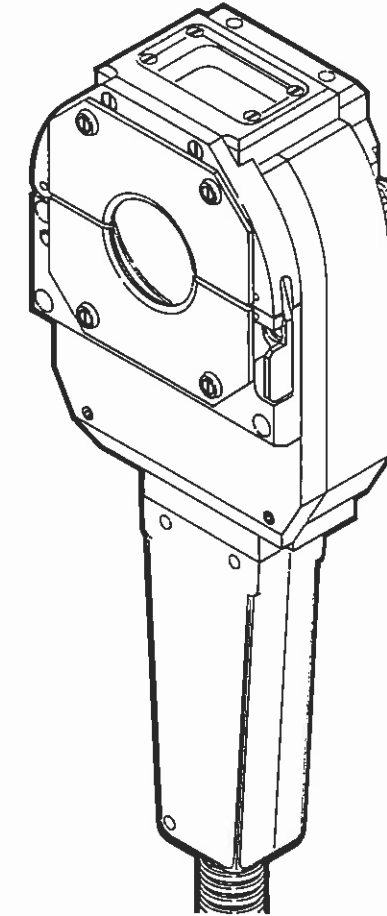

MODEL 9E

- NOTES :**
1. TO ORDER MODEL 9E KIT SPECIFY WELD HEAD MODEL NUMBER.
 2. MODEL 9-2500 USED FOR ILLUSTRATION.
 3. WIDE CLAMP INSERT AND GAS SEAL ARE NOT INCLUDED IN KIT.
TO ORDER WIDE CLAMP INSERT AND GAS SEAL SPECIFY TUBE SIZE (O.D.).

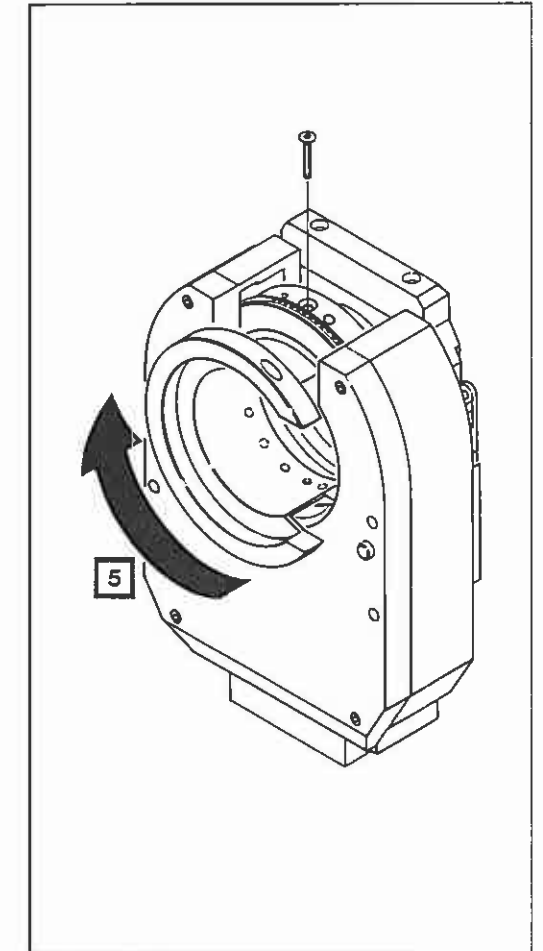
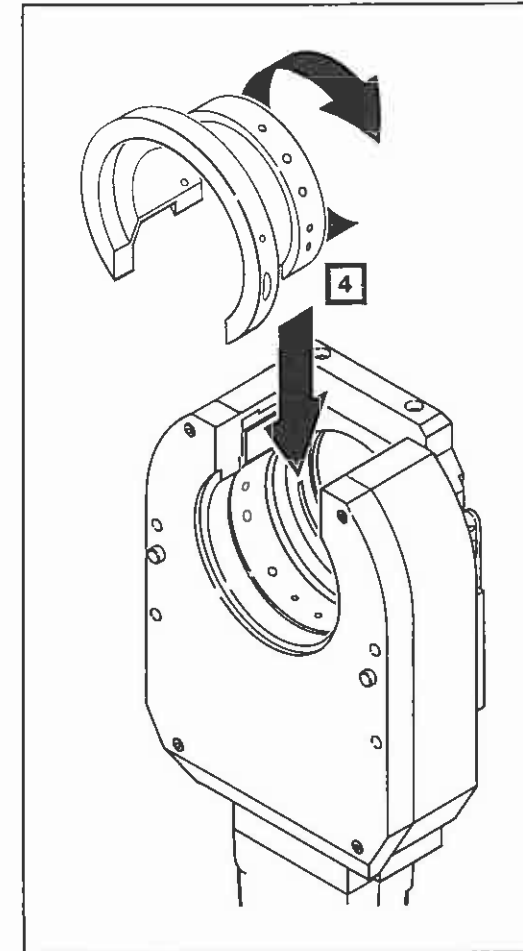
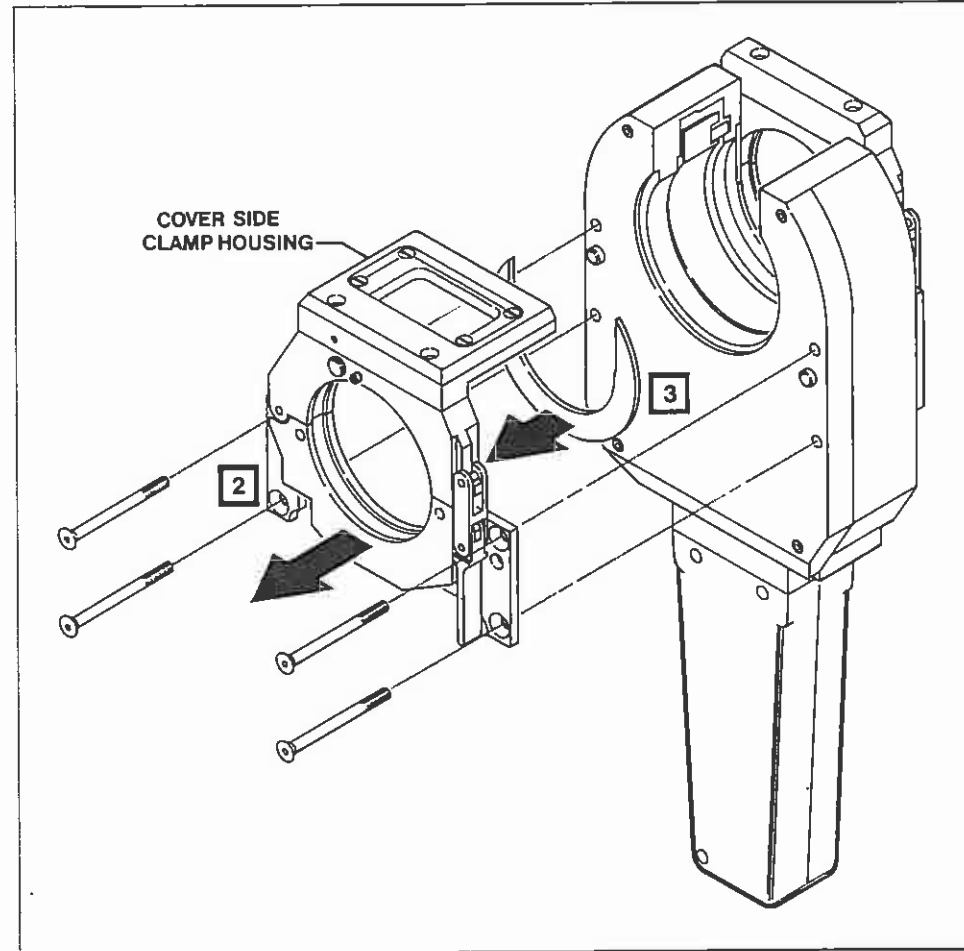
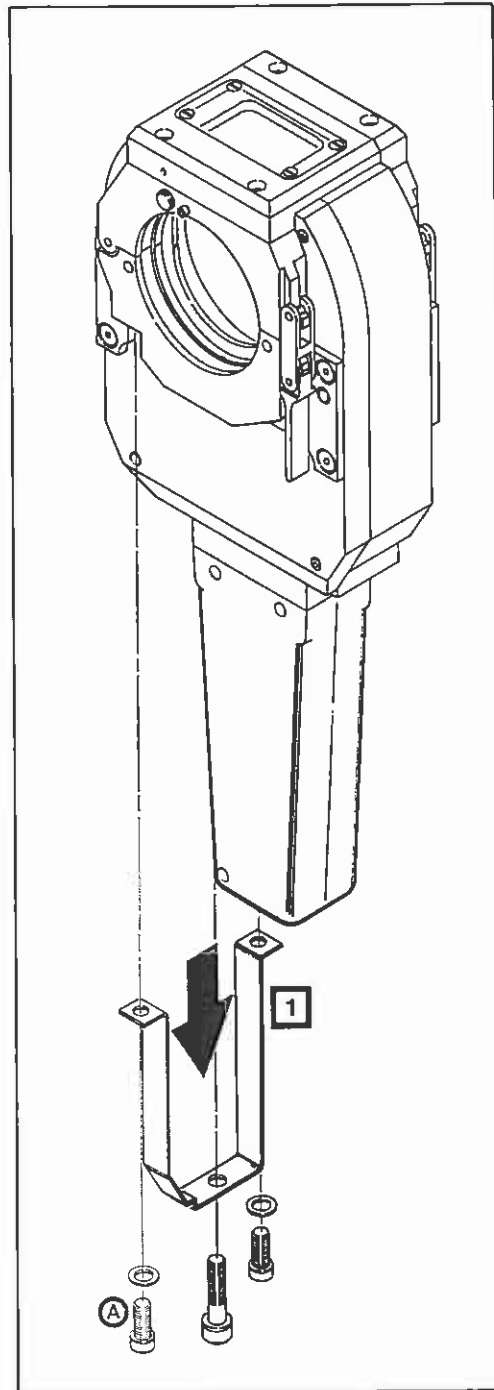

- 1** REMOVE ORIGINAL GROUND STRAP EXCEPT ON MODEL 9-1500 REMOVE SCREW **(A)** ONLY (ORIGINAL GROUND STRAP IS USED).
- 2** REMOVE COVER SIDE CLAMP HOUSING.
- 3** REMOVE HEAT SHIELD.
- 4** INSTALL ROTOR EXTENSION FROM THE KIT.
- 5** CONNECT WELD HEAD TO POWER SUPPLY AND JOG ROTOR UNTIL ROTOR EXTENSION MOUNTING SCREW HOLE IS ACCESSIBLE. INSTALL MOUNTING SCREWS (2 TO 4 EACH DEPENDING ON MODEL #) AND TIGHTEN.

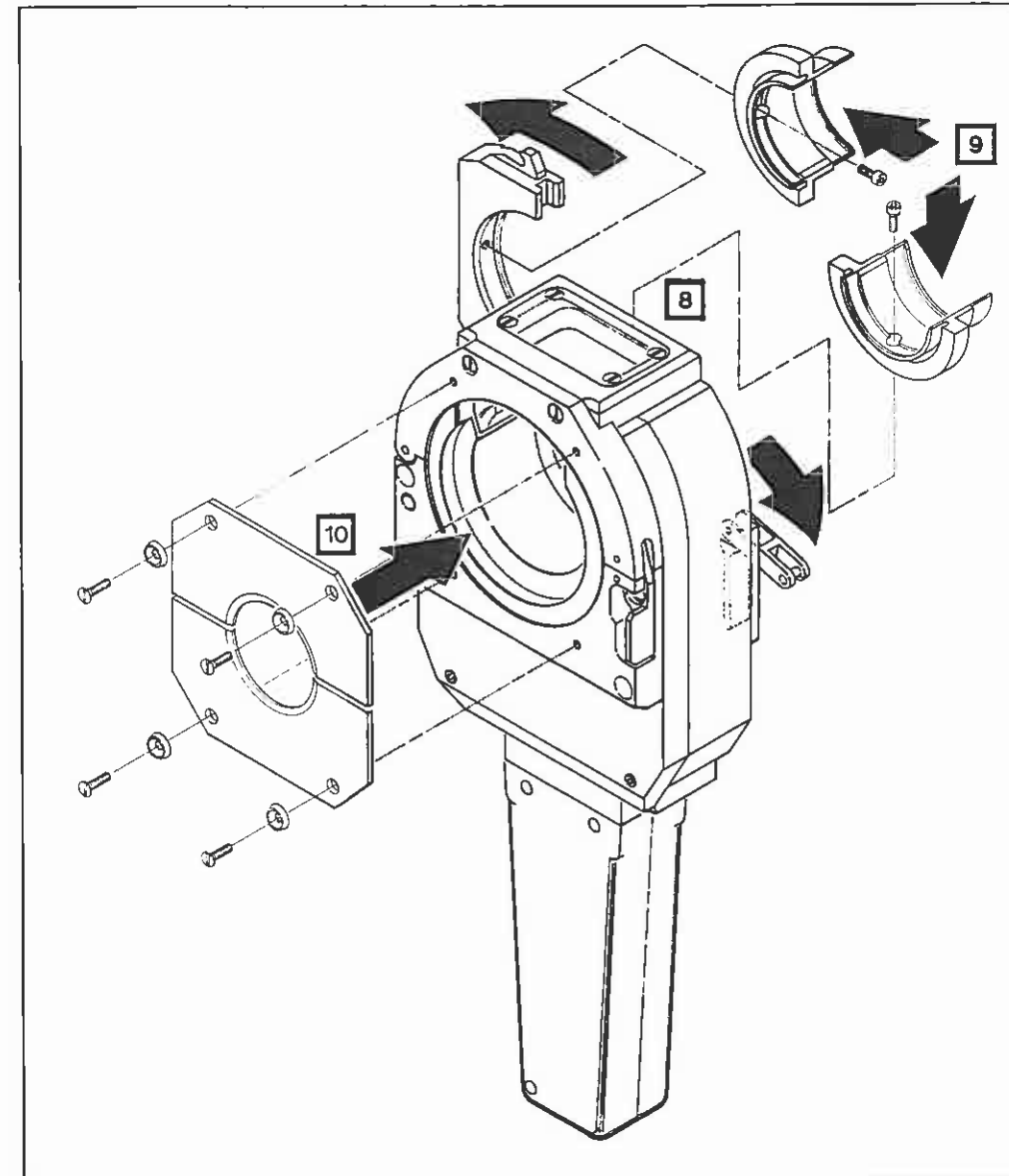
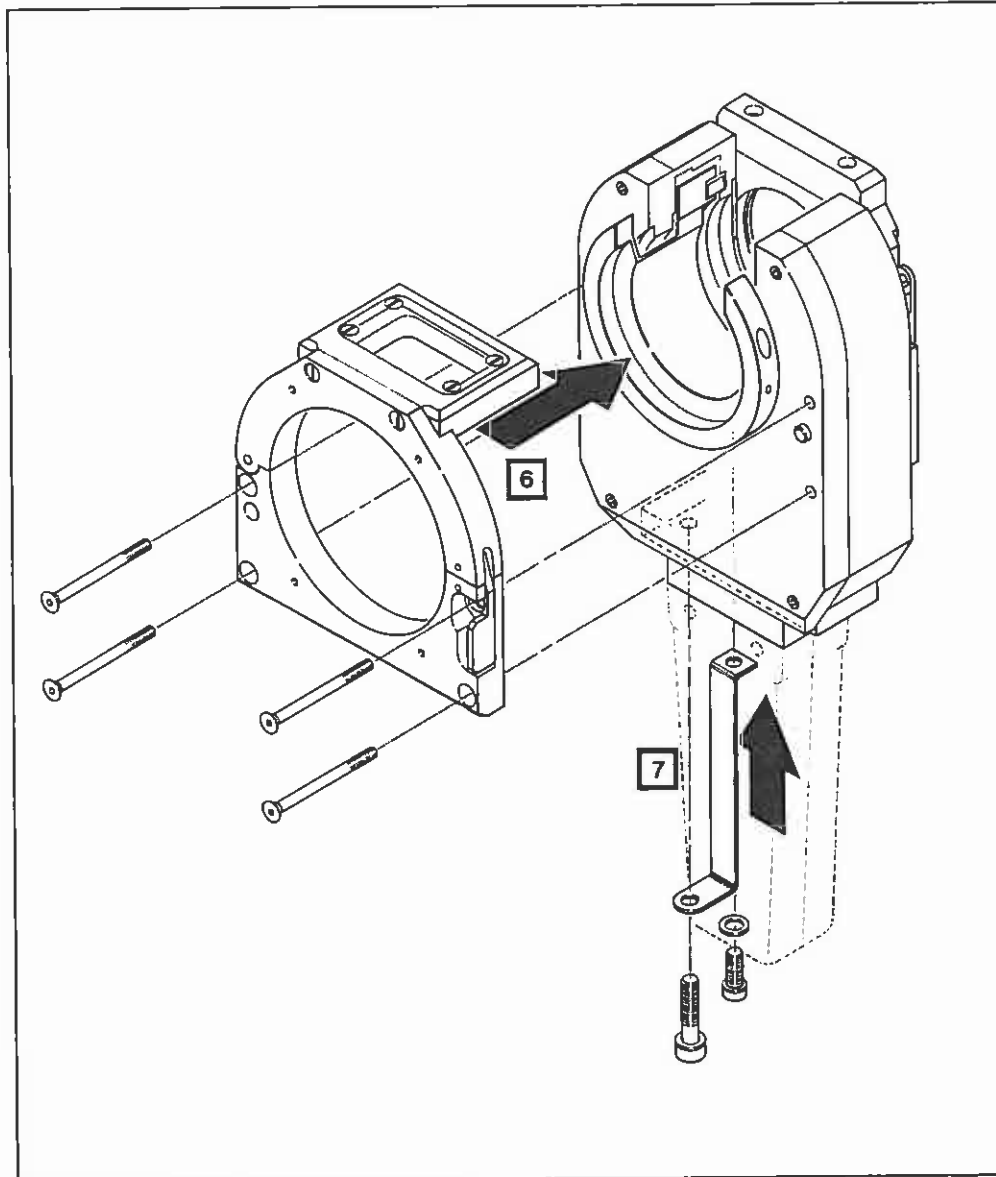

- 6** MOUNT THE GAS SEAL HOUSING ASSEMBLY FROM THE KIT TO THE WELD HEAD USING ORIGINAL SCREWS.
- 7** INSTALL GROUND STRAP FROM THE KIT USING ORIGINAL SCREWS, EXCEPT FOR MODEL 9-1500 USE ORIGINAL GROUND STRAP AND SCREWS.
- 8** OPEN HOUSING SIDE CLAMP.
- 9** INSTALL WIDE CLAMP INSERT ASSEMBLY (NOT PROVIDED IN CONVERSION KIT).
- 10** INSTALL GAS SEAL ASSEMBLY (NOT PROVIDED IN CONVERSION KIT).

To be used for reference only

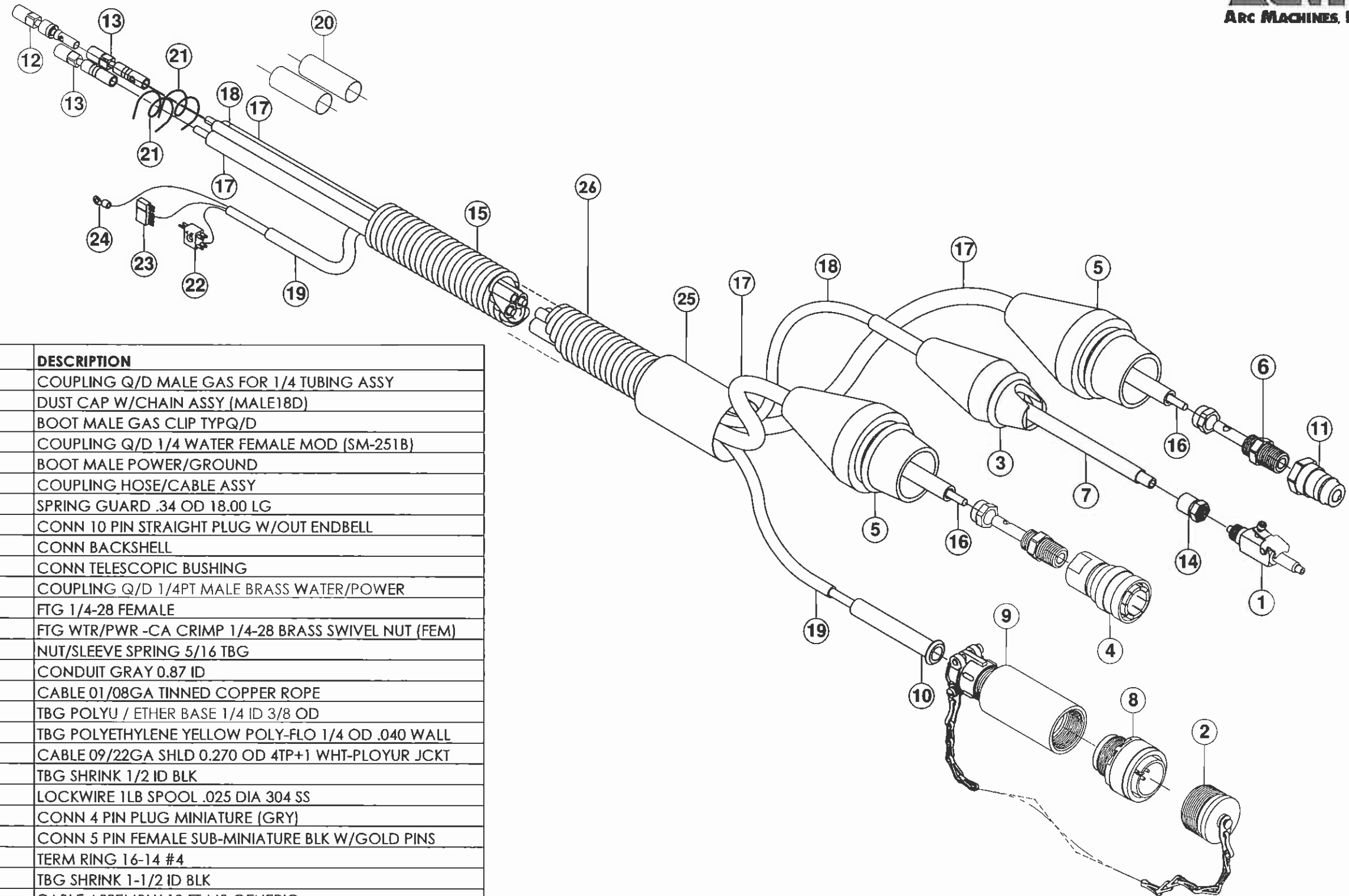

ITEM NO.	QTY.	PART NO.	DESCRIPTION
1	1	1351109-01	COUPLING Q/D MALE GAS FOR 1/4 TUBING ASSY
2	1	1350110-04	DUST CAP W/CHAIN ASSY (MALE18D)
3	1	42060805-04	BOOT MALE GAS CLIP TYPQ/D
4	1	42060800-02	COUPLING Q/D 1/4 WATER FEMALE MOD (SM-251B)
5	2	42060804-01	BOOT MALE POWER/GROUND
6	2	42060800-07	COUPLING HOSE/CABLE ASSY
7	1	AS200718	SPRING GUARD .34 OD 18.00 LG
8	1	MS3106E18-1PF42	CONN 10 PIN STRAIGHT PLUG W/OUT ENDBELL
9	1	G1501N186A3A	CONN BACKSHELL
10	1	MS39056-3	CONN TELESCOPIC BUSHING
11	1	SM-252B	COUPLING Q/D 1/4PT MALE BRASS WATER/POWER
12	1	2PF1	FTG 1/4-28 FEMALE
13	2	ARC-1881	FTG WTR/PWR -CA CRIMP 1/4-28 BRASS SWIVEL NUT (FEM)
14	1	261-PG-04	NUT/SLEEVE SPRING 5/16 TBG
15	1	DUCT-0.87-50-G	CONDUIT GRAY 0.87 ID
16	2	NER7-95-36T	CABLE 01/08GA TINNED COPPER ROPE
17	2	42090806-01	TBG POLYU / ETHER BASE 1/4 ID 3/8 OD
18	1	44-P-YELLOW	TBG POLYETHYLENE YELLOW POLY-FLO 1/4 OD .040 WALL
19	1	CWT11943	CABLE 09/22GA SHLD 0.270 OD 4TP+1 WHT-PLOYUR JCKT
20	2	M23053/5-108-0	TBG SHRINK 1/2 ID BLK
21	2	MS20995C25	LOCKWIRE 1LB SPOOL .025 DIA 304 SS
22	1	JF2P2SCD	CONN 4 PIN PLUG MINIATURE (GRY)
23	1	7052	CONN 5 PIN FEMALE SUB-MINIATURE BLK W/GOLD PINS
24	1	34119	TERM RING 16-14 #4
25	1	M23053/5-111-0	TBG SHRINK 1-1/2 ID BLK
26	-	13090800-01	CABLE ASSEMBLY 10 FT M9 GENERIC

**MODEL 9
IPB 090800
CABLE ASSEMBLY**

To be used for reference only

TO ORDER USE PART NUMBER.
PRICE, PART NUMBER AND DESCRIPTION
SUBJECT TO CHANGE WITHOUT NOTICE.

Property of Arc Machines, Inc.
**THIS IPB SUPERSEDES ALL OTHER IPB'S
REFERENCING 13090800-01 CABLE ASSEMBLY**

ISSUED: 3 JAN 2005
REVISED: 5 OCT 2010

LTR	DOC	REVISIONS	DATE	BY	APPR
A	1716	CEP ON PJ-10 REVISED	11-24-92	MH	
B	2847	ADDED P10A & J10A - REMOVED PN'S FOR P10A, J10A, P4	12-4-97	MC	GAC

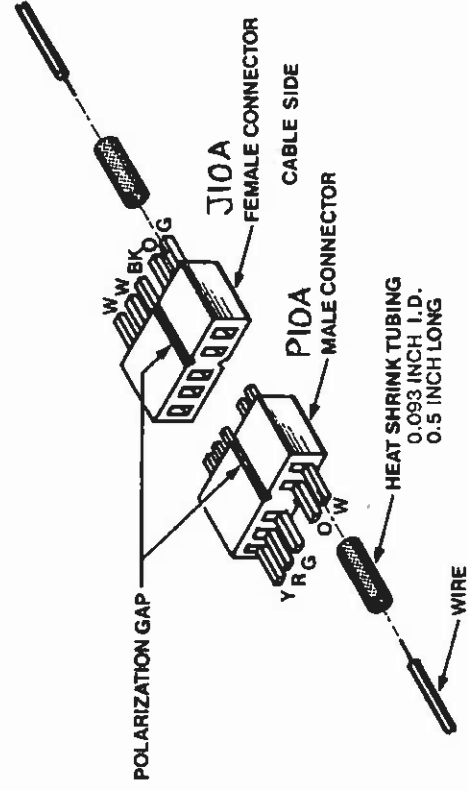
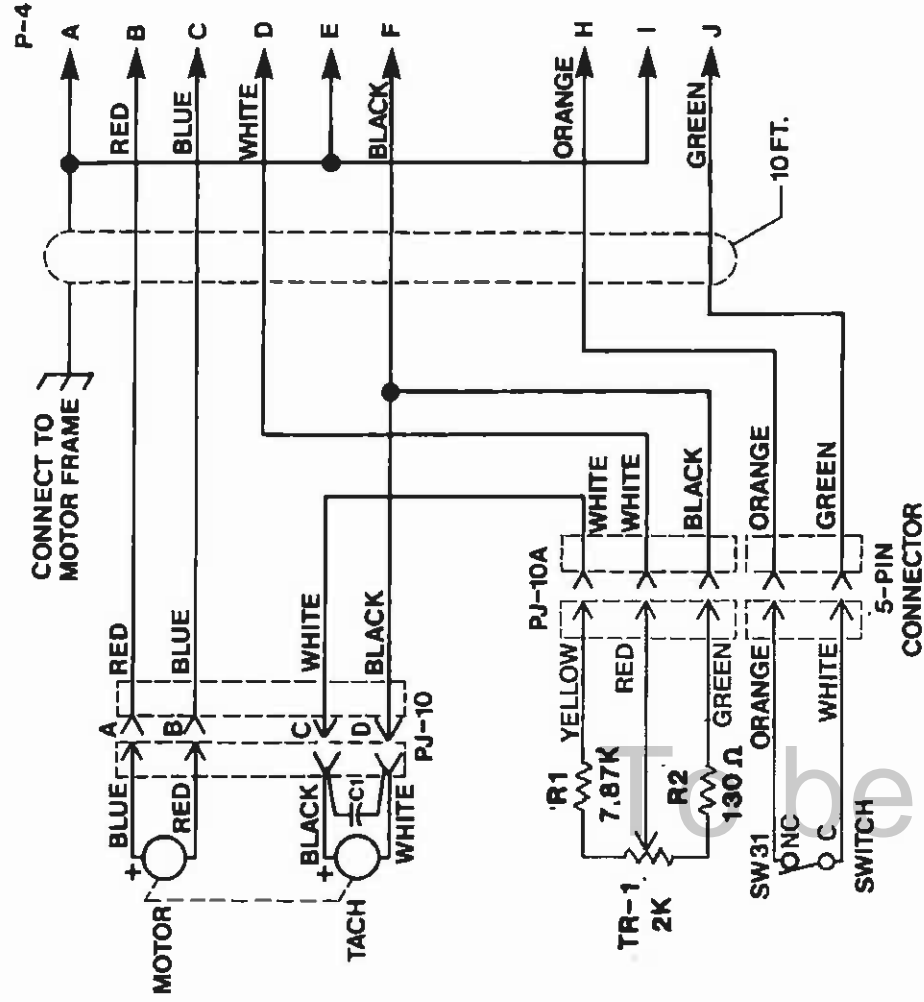

ITEM	QTY	IDENTIFYING NO	NOMENCLATURE OR DESCRIPTION	MFR.	PART NO
PARTS LIST					
<small>THIS DOCUMENT OR DRAWING AND THE INFORMATION CONTAINED HEREIN IS THE PROPERTY OF ARC MACHINES, INC. IT IS PROPRIETARY. IT IS SUBMITTED AND FORWARDED TO YOU FOR YOUR INFORMATION ONLY. IT IS NOT TO BE REPRODUCED OR TRANSMITTED IN ANY FORM OR BY ANY MEANS, ELECTRONIC OR MECHANICAL, INCLUDING PHOTOCOPYING, RECORDING, OR BY ANY INFORMATION STORAGE AND RETRIEVAL SYSTEM, WITHOUT THE WRITTEN PERMISSION OF ARC MACHINES, INC.</small>					
<small>UNLESS OTHERWISE SPECIFIED ALL DIMENSIONS ARE IN INCHES TOLERANCES ARE FRACTIONS DECIMALS ANGLES ± 1/16 ± .005 ± .010 ± .001 ± .001 ± .001 ± .001</small>					
THIRD ANGLE PROJECTION		FOR MAILED STAMPS SEE DOC-STD-00		DATE	REV.
		APPROVALS		10-14-85	A
		R. BILEK		10-16-85	B
		(MR)			
ALL DIMENSIONS SURFACES TO BE		MATERIAL		MODEL NO.	175144-04
NEXT ASSY.		USED ON		SIZE	A
APPLICATION				SCALE	DO NOT SCALE DRAWING
				QUOTATION	SHEET 1 OF 1

ARC MACHINES INC.
MODEL 9 WELD HEAD
WIRING DIAGRAM