

MODEL 9-3500
ILLUSTRATED PARTS BREAKDOWN



Property of Arc Machines, Inc.

MODEL 9-3500
IPB Notice and Revision History

This document and the information contained herein is the property of Arc Machines, Inc. It is proprietary and submitted and received in confidence. It shall be used only for the purpose for which it is submitted and shall not be copied in whole or in part without the prior express written permission of Arc Machines, Inc. The information in this document has been carefully reviewed and is believed to be accurate. However, no responsibility is assumed for inaccuracies. Information and part numbers in this document are subject to change and Arc Machines, Inc. reserves the right to change required data without notice.

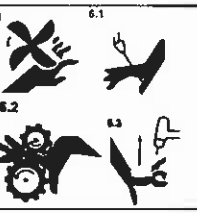

The nature of the GTAW process creates some POTENTIAL HAZARDS. In accordance with international safety regulations the EXCLAMATION SYMBOL indicates that this equipment is considered HAZARDOUS. The LIGHTNING FLASH SYMBOL indicates that there are potential electrical hazards. The display of these symbols makes it the OPERATOR'S RESPONSIBILITY TO ENSURE THAT THEY HAVE BEEN MADE AWARE OF and shall observe the hazardous conditions.

	WARNING: AMI factory training is essential for all Maintenance Technicians who operate AMI equipment. Do not operate or service this equipment without proper AMI approved training.
	WARNING: Keep hands and fingers clear from moving parts such as fans, gears, rotors, Wire Feed, Weld Head Travel, i.e. Oscillation (OSC) and Arc Voltage Control (AVC) mechanisms Weld Head AVC and Oscillator Slide Assemblies develop high forces and it is possible, by their nature of operation, to harm any object or body part that may get into these areas. USE EXTREME CAUTION!
	Electrical Shock Hazard: Always disconnect weld heads when servicing internal components or opening housing covers for access.

All rights reserved.
Publication date: First Edition – June 5, 2007
Copyright 2007 by Arc Machines, Inc.

REV	ECO #	CHANGE DESCRIPTION	DATE	BY	APR
A	4678	On 090117 Change Item 6 & 23	7 Mar 2008	SO	BF
B	4779	Added rev D of 750015	26 May 2008	SO	BF
C	5579	Added rev F of 750015 and Wiring Diagram	18 Jan 2010	CB	DC
D	5753	Deleted pg 4 of 8 from IPB 090117, removed cable parts from 090117, updated TOC	10/6/10	GB	DC

To be used for reference only

Property of Arc Machines, Inc.

TABLE OF CONTENTS

DATE EFFECTIVE: 29 July 1992

PRODUCT MODEL: 9-3500
MANUAL NUMBER: 730023

IPB NUMBER	DESCRIPTION
750015	MODEL 9 ELECTRODE DIMENSIONS
090117	MAIN ASSEMBLY
090515	LOCATING ARM KIT
090104	MODEL 9E CONFIGURATION
750031	MODEL 9 CONVERSION TO MODEL 9E INSTRUCTIONS
090800	CABLE ASSEMBLY M9
175144-04	MODEL 9 WELD HEAD WIRING DIAGRAM

To be used for reference only

ELECTRODE DIMENSIONS

ROTOR DIAMETER	
MODEL NO.	ROTOR O.D.
9-250	0.802
9-500/4-500	1.388
9-675	1.715
9M-750	1.312
9-750	2.000
9-1500	3.187
9AF-1500	2.252
9E-1500	2.687
8-2000	3.450
9-2500	4.380
9AF-2500	3.156
9E-2500	4.280
* 9-3500	5.380
9E-3500	5.310
8-4000	5.310
* 9-4500	6.875
9ER-4500	5.776
8-6625	8.094
* 9-7500	10.440
9E-7500	9.375
* FOR HEADS USING OPTIONAL TUNGSTEN EXTENDER, SEE PAGE 2.	

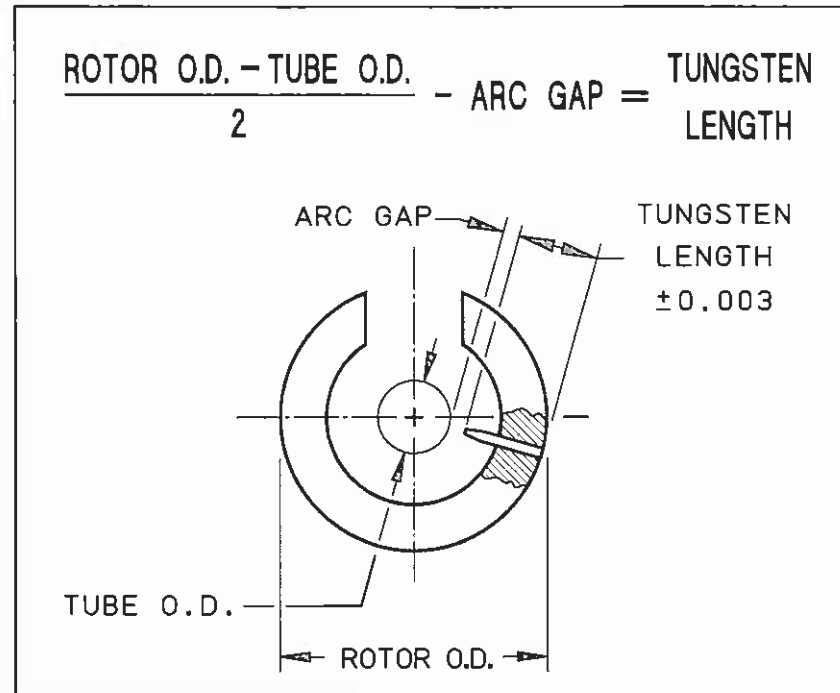

TUBE/PIPE WALL THICKNESS	RECOMMENDED ARC GAP	RECOMMENDED TIP DIA.
0.020/0.035	0.030	0.020
0.049/0.085	0.050	0.030
0.091/0.154	0.070	0.040

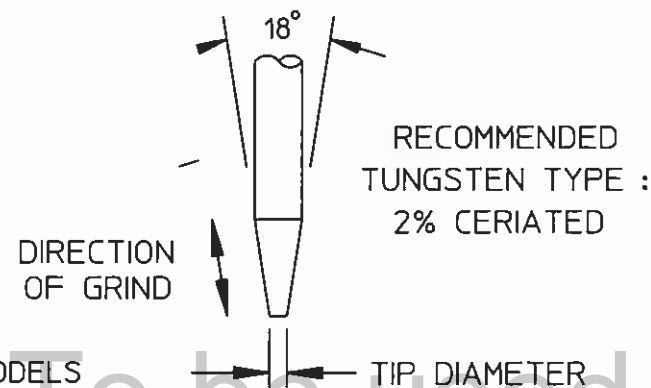

- NOTES:
1. RECOMMENDED ARC GAP FOR MODELS 4-500, 9-250 & 9-500 IS 0.045 MAXIMUM.
 2. IN INSTANCES WHERE OUT-OF-ROUNDNESS ON THIN-WALLED TUBING OCCURS (NORMALLY 2.500 O.D. OR LARGER), A 0.070 ARC GAP IS RECOMMENDED.
 3. DIMENSIONS ARE IN INCHES.

TUNGSTEN LENGTH CALCULATION FOR TUNGSTEN EXTENDERS

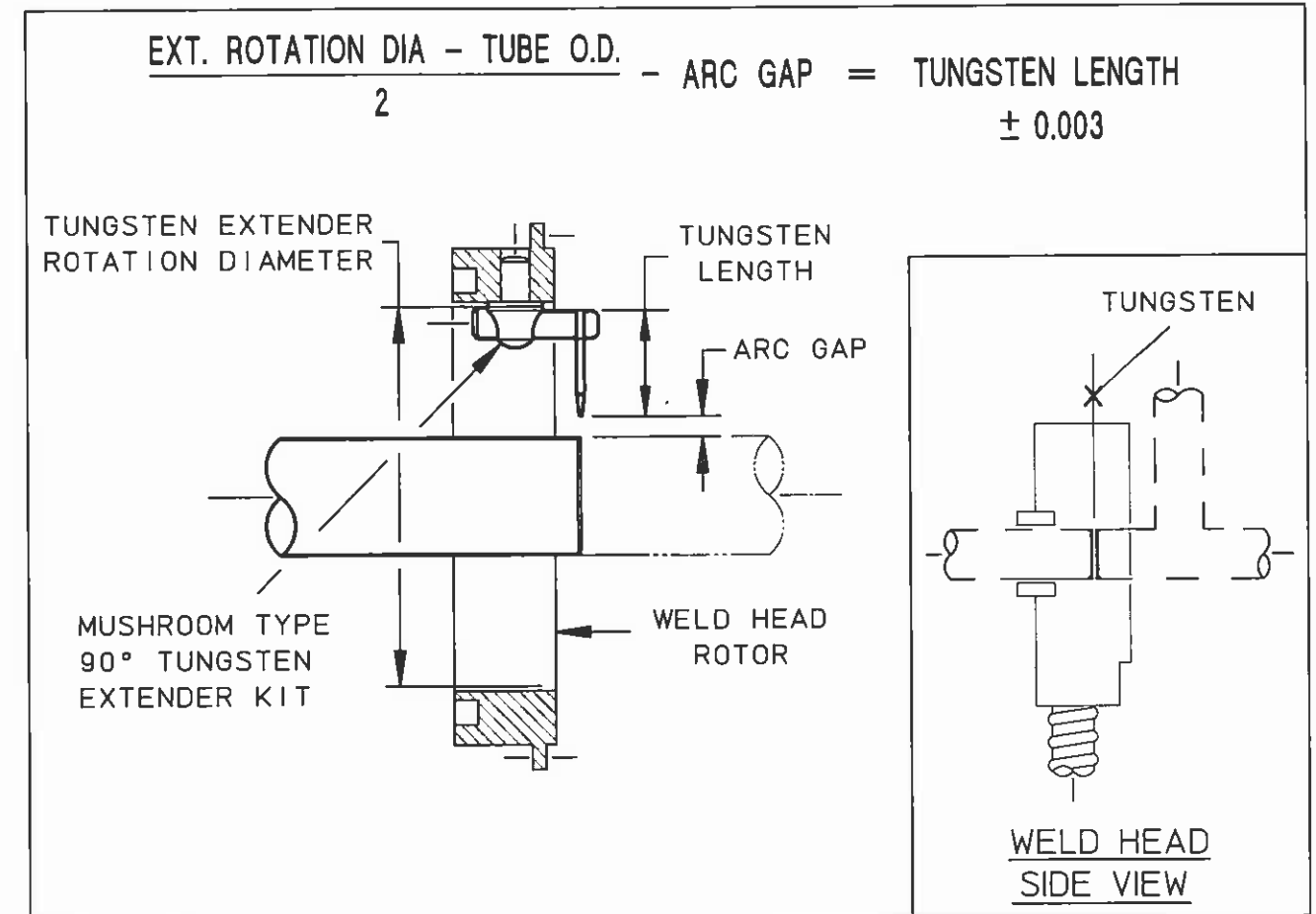

WELD HEAD MODEL NO.	KIT WITH 1/16 TUNGSTEN HOLDER PART NO.	KIT WITH 3/32 TUNGSTEN HOLDER PART NO.	TUNGSTEN EXTENDER ROTATION DIA.
9-1500	13090796-01	13090796-02	2.031
9-2500	13090796-05	13090796-06	3.156
9-3500	13090796-05	13090796-06	4.031
9-4500	13090796-03	13090796-04	4.920
9-7500	13090796-05	13090796-06	8.280

NOTES:

1. PART NUMBERS SHOWN ARE FOR REFERENCE ONLY AND ARE SUBJECT TO CHANGE.
2. CONTACT AMI SALES OR SERVICES FOR SPECIFIC PART NUMBER.

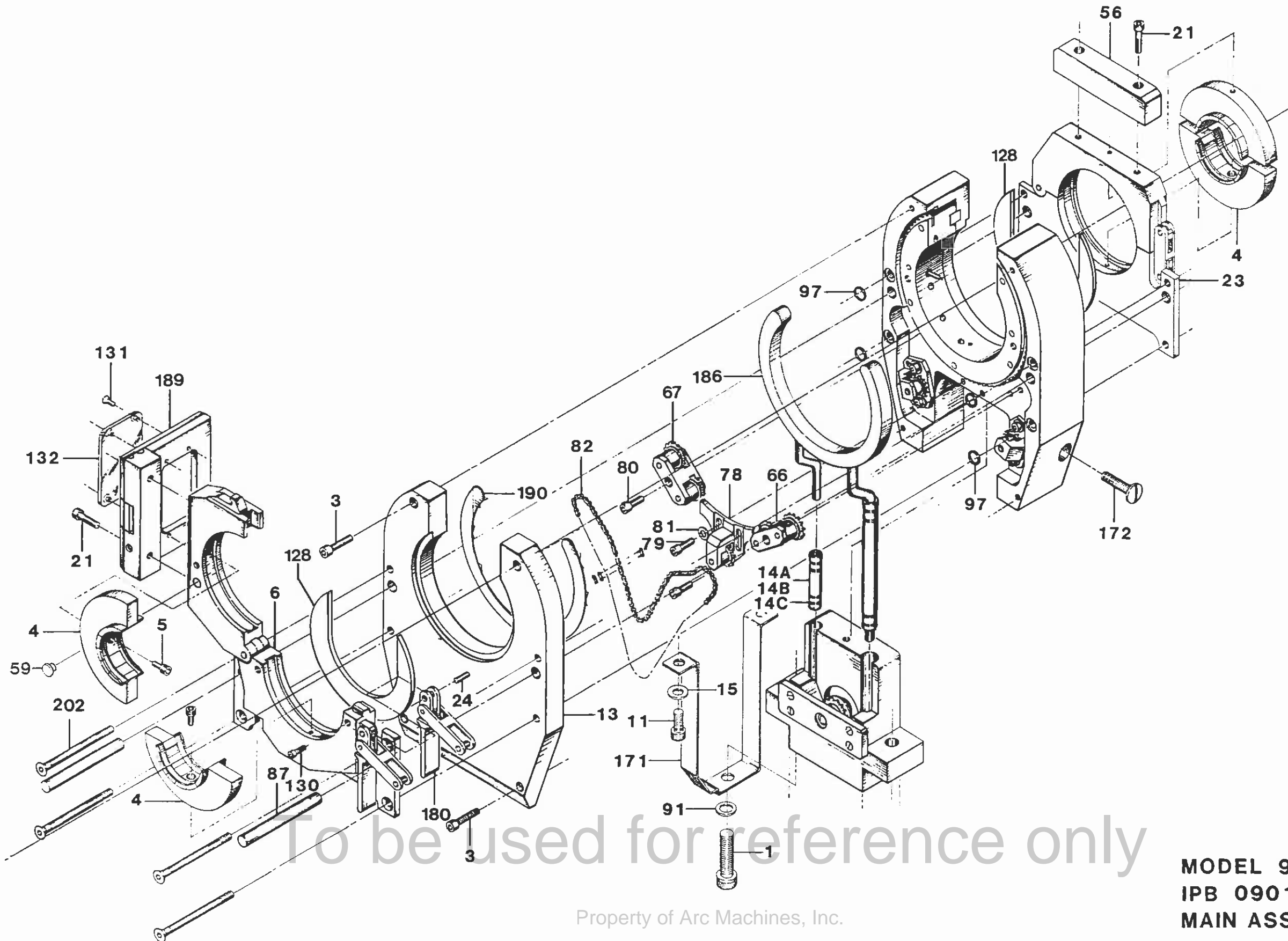

To be used for reference only

Property of Arc Machines, Inc.

MODEL 9-3500
IPB 090117
MAIN ASSEMBLY

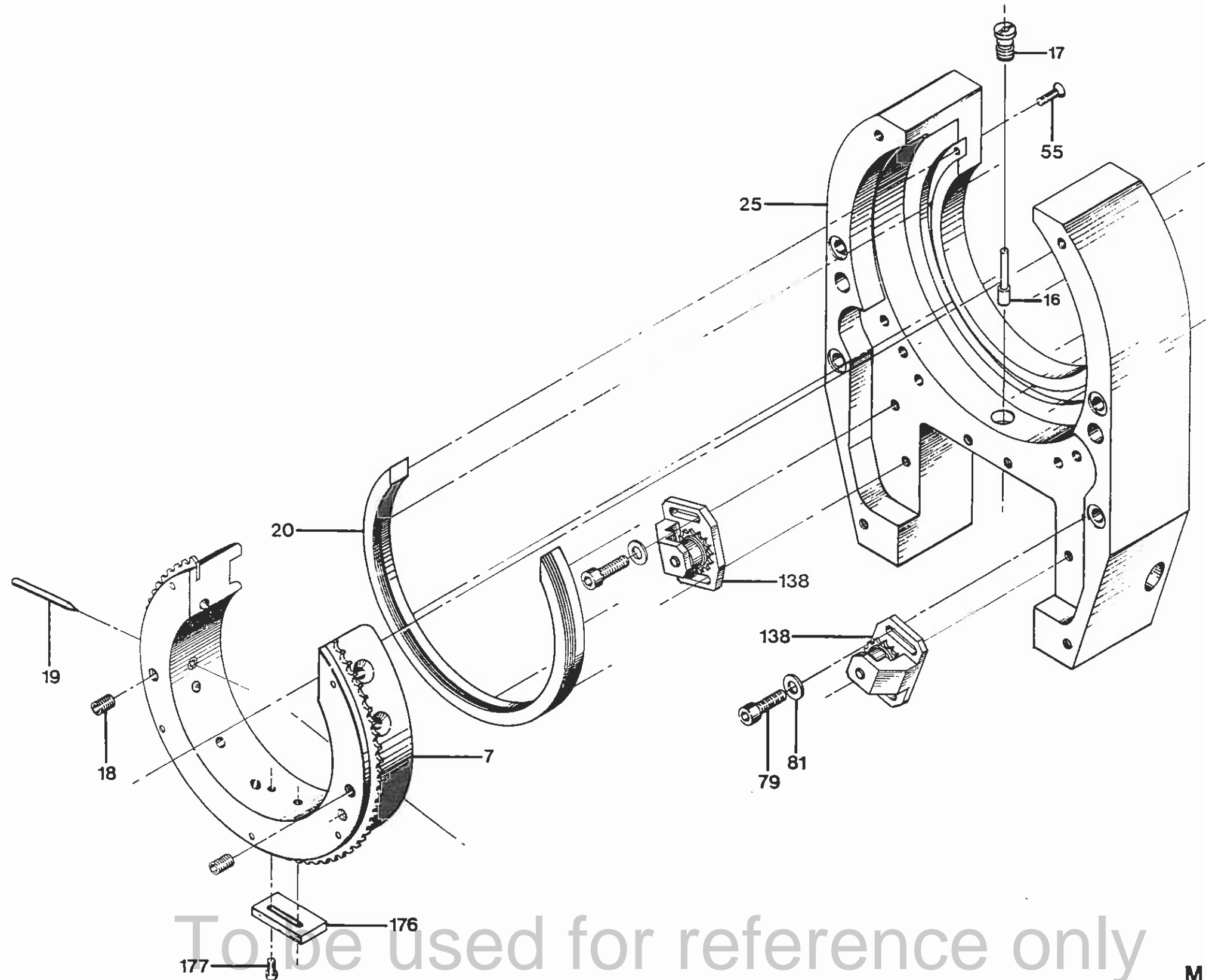

To be used for reference only

Property of Arc Machines, Inc.

MODEL 9-3500
IPB 090117
HOUSING ASSEMBLY

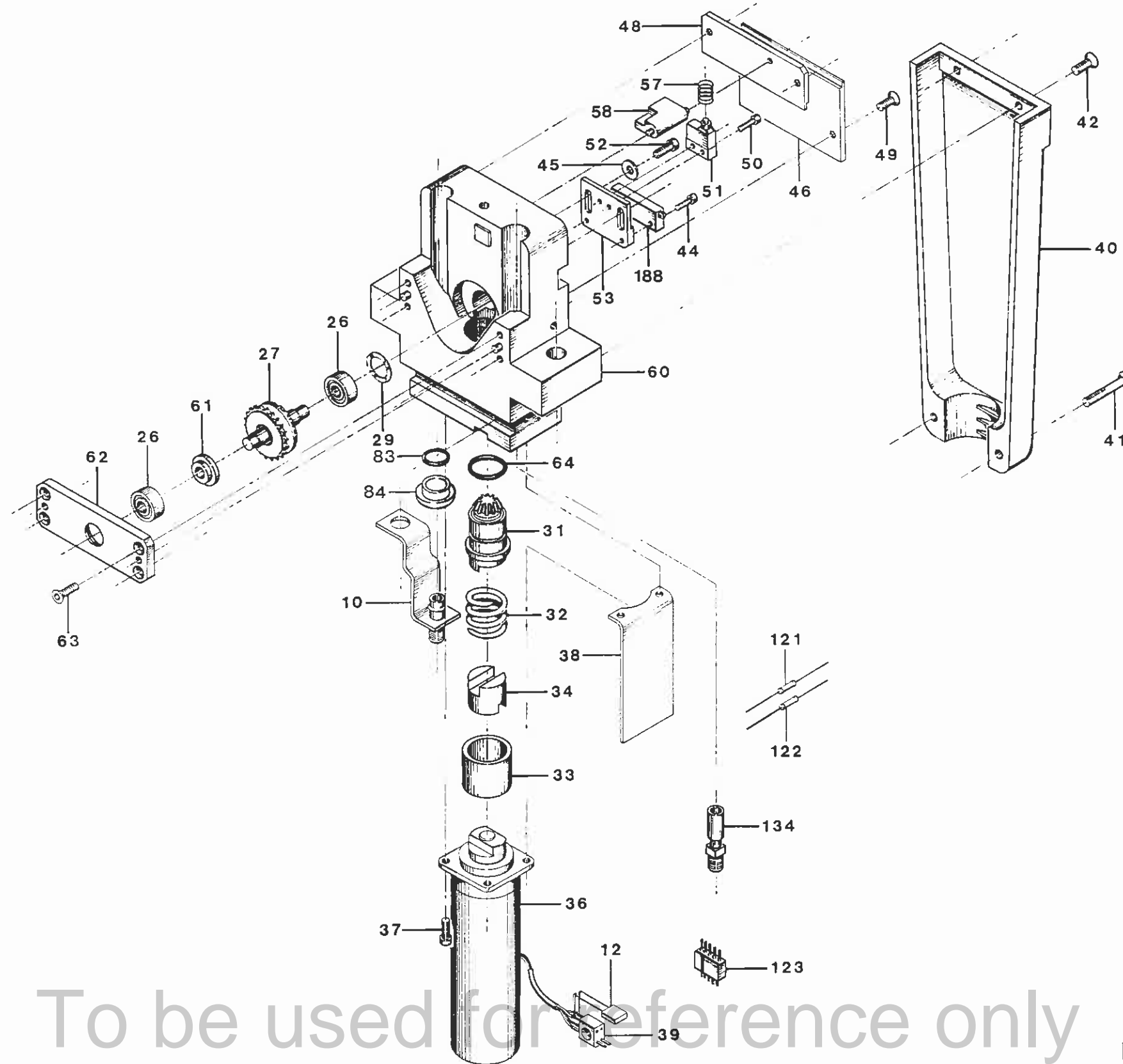

To be used for reference only

Property of Arc Machines, Inc.

MODEL 9-3500
IPB 090117
DRIVE ASSEMBLY

THIS DOCUMENT OR DRAWING AND THE INFORMATION CONTAINED HEREIN IS THE PROPERTY OF ARC MACHINES, INC. IS PROPRIETARY IS SUBMITTED AND RECEIVED IN CONFIDENCE. SHALL BE USED ONLY FOR THE PURPOSE FOR WHICH IT IS SUBMITTED AND SHALL NOT BE COPIED IN WHOLE OR IN PART WITHOUT THE PRIOR EXPRESS WRITTEN PERMISSION OF ARC MACHINES, INC.



ARC MACHINES, INC.

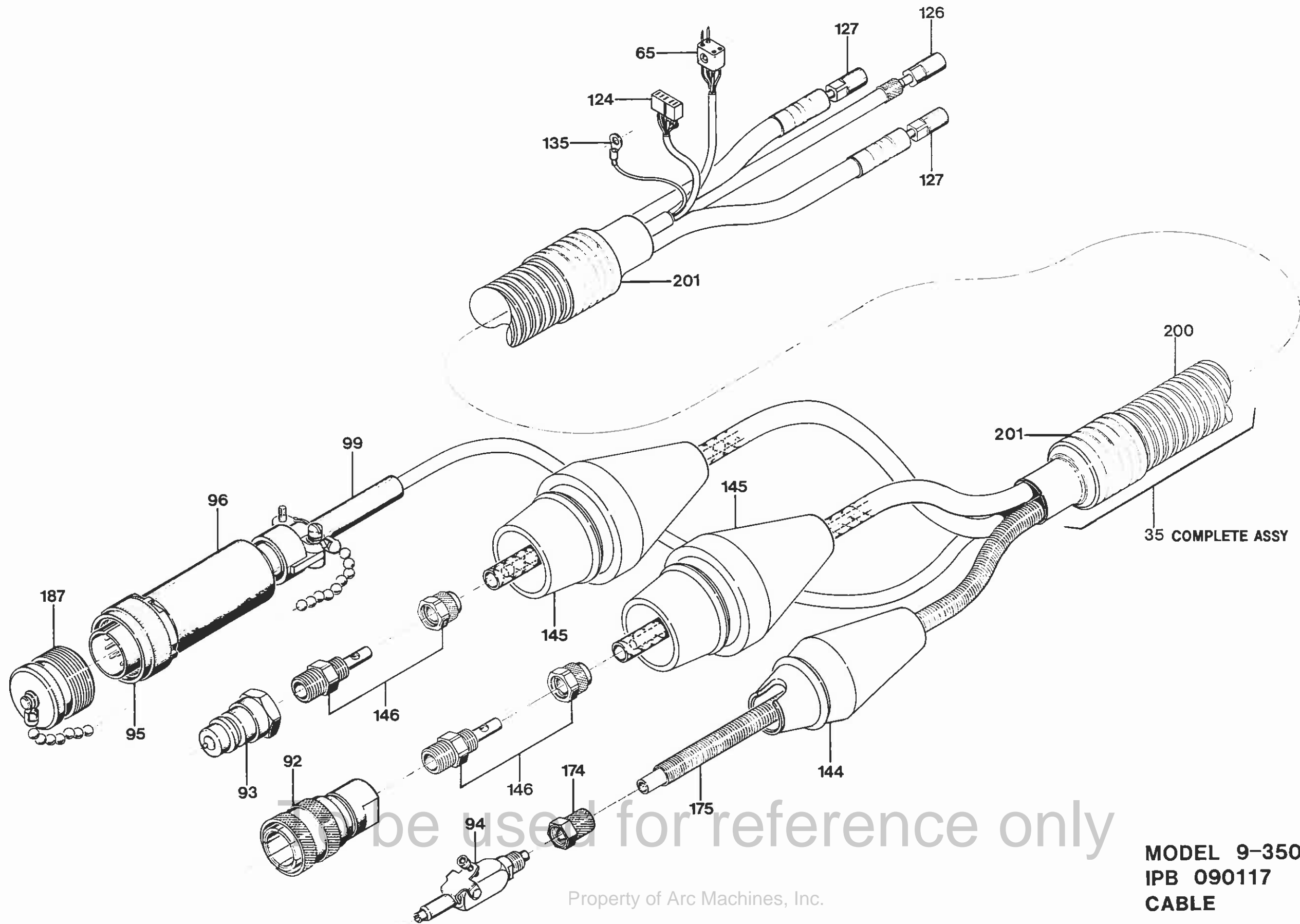

Property of Arc Machines, Inc.

MODEL 9-3500
IPB 090117
CABLE

IPB NUMBER: 090117

TO ORDER
USE PART NUMBER
DO NOT USE IPB
ITEM NUMBER

ARC MACHINES, INC.

PRODUCT MODEL: 9-3500
DESCRIPTION: MAIN ASSEMBLY
MANUAL NUMBER: 730023
NOTES:

IPB ITEM NUMBER	QTY	U/M	PART NUMBER	DESCRIPTION	
1	2	EA	SCS31-18-1.25NP	SCREW CAP SKT 5/16-18 1-1/4 L	
2	0	-	-	-----	
3	4	EA	SCS08-32-0.87NP	SCREW CAP SKT 8-32 7/8 L	
4	0	-	-	-----	TUBE CLAMP INSERT-ORD BY SIZE
5	4	EA	SCS06-32-0.37NP	SCREW CAP SKT 6-32 3/8 L	
6	1	EA	130905273-01	CLAMP HSG COVER SIDE	ITEMS 24, 59 & 180 INCLUDED
7	1	EA	13090773-01	ROTOR 9-3500	ITEMS 18, 176 AND 177 INCLUDED
8	0	-	-	-----	
10	1	EA	13090723-01	GROUND STRAP	
11	2	EA	SCS25-20-0.62SP	SCREW CAP SKT 1/4-20 5/8 L SP	
12	1	EA	CK06BX104K	CAP 0.1MF 100V 10%	
13	1	EA	42090159-01	COVER	
14A	0.5	FT	029173	TBG SILICONE 1/8ID 1/4OD RED	
14B	0.08	FT	FP-301-0.25	TBG SHRINK	
14C	18	IN	MS20995C25	LOCKWIRE 1LB SPOOL .025D 304SS	
15	2	EA	W25NP-FL	WASHER FL 1/4	
16	1	EA	42091109-06	PIN ACT 9-3500	
17	1	EA	42091110-01	BUSHING ACTUATOR	
18	3	EA	SSS06-32-18NPCU	SCREW SET SKT 6-32 3/16 L CUPT	
19	0	-	-	-----	TUNGSTEN
20	1	EA	42090778-01	GUIDE RING	
21	4	EA	SCS10-32-1.00NP	SCREW CAP SKT 10-32 1.00 L	
22	0	EA	-	-----	
23	1	EA	130905272-01	CLAMP HSG HSG SIDE	ITEMS 180 AND 24 INCLUDED
24	2	EA	PD12-0.31SS	PIN DOWEL 1/8D 5/16L SST	
25	1	EA	42090158-01	HOUSING UPPER	ITEMS 16, 17, 60 & 172 INC.
26	2	EA	SSR-3LLRA3P2[BEARING BALL .18 .50 [5LY-101]	
27	1	EA	13090613-01	GEAR BEVEL	
28	0	-	-	-----	
29	1	EA	SV-8	SPRING WAVE WASHER .351D .44	
30	0	-	-	-----	
31	1	EA	13090602-07	GEAR PINION DRIVE	
32	1	EA	15156	SPRING CPRSN .81D .70L .067W	
33	1	EA	42090602-04	SPACER SPRING	
34	1	EA	42090602-03	COUPLING INSULATING DELRIN	
35	1	EA	13090800-01	CABLE M9 10 FT	
36	1	EA	13090602-03	MOTOR DRIVE PINION 81 RPM	ITEMS 12 AND 39 INCLUDED

To be used for reference only

PRICE, PART NUMBER AND
DESCRIPTION SUBJECT TO
CHANGE WITHOUT NOTICE

IPB NUMBER: 090117

TO ORDER
USE PART NUMBER
DO NOT USE IPB
ITEM NUMBER

ARC MACHINES, INC.
PRODUCT MODEL: 9-3500
DESCRIPTION: MAIN ASSEMBLY
MANUAL NUMBER: 730023
NOTES:

IPB ITEM NUMBER	QTY	U/M	PART NUMBER	DESCRIPTION
37	4	EA	SCS04-40-0.31NP	SCREW CAP SKT 4-40 5/16 L
38	1	EA	42091102-04	INSULATOR SKIRT
39	1	EA	JF2P2SCD	CONN 4 PIN PLUG MINIATURE
40	2	EA	42090104-01	HANDLE
41	2	EA	SFS04-40-1.00NP	SCREW FLH SKT 4-40 1.00 L
42	4	EA	SFS04-40-0.37NP	SCREW FLH SKT 4-40 3/8 L
43	0	-	-	-----
44	2	EA	SCS02-56-0.25NP	SCREW CAP SKT 2-56 1/4 L
45	2	EA	W04ZP-FL	WASHER FLAT #4
46	1	EA	42090619-02	COVER PLATE BOT LIMIT SW
47	0	-	-	-----
48	1	EA	42090619-01	COVER PLATE TOP LIMIT SW
49	4	EA	SFS04-40-0.31NP	SCREW FLH SKT 4-40 5/16 L
50	2	EA	SCS02-56-0.25NP	SCREW CAP SKT 2-56 1/4 L
51	1	EA	MMGGD1DOC	SWITCH LIMIT PLUNGER
52	2	EA	SCS04-40-0.25NP	SCREW CAP SKT 4-40 1/4 L
53	1	EA	42090616-05	PLATE LIMIT SWITCH
54	0	-	-	-----
55	7	EA	SFL06-32-0.50NY	SCREW FLH SLT 6-32 1/2 L NYL
56	1	EA	42090597-02	CLOSURE
57	1	EA	L-14	SPRING CPRSN .25D .43L .020W
58	1	EA	42091108-03	LEVER LIMIT SW ACTR
59	1	EA	650	PLUG 1/4 DIA HOLE
60	1	EA	42090146-01	HOUSING DRIVE
61	1	EA	42090617-02	SPACER BEVEL GEAR
62	1	EA	42090548-02	RETAINER PLATE
63	4	EA	SFS04-40-0.37NP	SCREW FLH SKT 4-40 3/8 L
64	1	EA	2-014-S604-70	O RING .489 ID .070 W SIL
65	1	EA	JF2P2PCD	CONN 4 SOCKET RECEPTACLE MINTR
66	1	EA	13090625-01	BRACKET H R/H
67	1	EA	13090625-02	BRACKET H L/H
77	0	-	-	-----
78	1	EA	13090630-01	TENSIONER CENTER
79	6	EA	SCS08-32-0.37NP	SCREW CAP SKT 8-32 3/8 L
80	2	EA	SCS08-32-0.75NP	SCREW CAP SKT 8-32 3/4 L
81	6	EA	W08NP-FL	WASHER FLAT #8
82	1	EA	RC14SS-139	OBS USE P/N 47SS-139

SEE ITEM 25

To be used for reference only
PRICE, PART NUMBER AND DESCRIPTION SUBJECT TO CHANGE WITHOUT NOTICE

IPB NUMBER: 090117

TO ORDER
USE PART NUMBER
DO NOT USE IPB
ITEM NUMBER

ARC MACHINES, INC.
PRODUCT MODEL: 9-3500
DESCRIPTION: MAIN ASSEMBLY
MANUAL NUMBER: 730023
NOTES:

IPB ITEM NUMBER	QTY	U/M	PART NUMBER	DESCRIPTION
83	1	EA	2-010-S604-70	O RING .238 ID .070 W SILICONE
84	1	EA	420901126-02	GROMMET
87	2	EA	42090164-03	PIN .312D 2.45L 9-2500
88	0	-	-	-----
89	0	-	-	-----
91	2	EA	W31ZP-FL	WASHER FL 5/16
92	1	EA	42060000 02	COUPLING Q/D CONN (GM 251B)
93	1	EA	SM252B	COUPLING
94	1	EA	294 PMD 04	DO NOT SELL USE: 1351109 01
95	1	EA	M63106E18 1P	CONN 18 PIN PLUG
96	1	EA	G1501N18CA3A	CONN BACKSHELL
97	4	EA	2-106-S604-70	O RING .174 ID .103 W SILICONE
98	0	-	-	-----
99	1	EA	M639056 3	CONN TELESCOPIC BUSHING
105	0	-	-	-----
106	0	-	-	-----
107	0	-	-	-----
121	1	EA	RN55D1300F	RES 130 OHMS 1/4W
122	1	EA	RN55D7871F	RES 7.87K
123	1	EA	5PM	OBS USE 7051
124	1	EA	5PF	OBS USE 7052
125	0	-	-	-----
126	1	EA	2FF1	FTG 1/4 20 FEMALE
127	2	EA	42060000 01	OBS (USE ARC 1881)
128	2	EA	420907159-01	HEAT SHIELD 9-3500
130	4	EA	SCS04-40-0.50NP	SCREW CAP SKT 4-40 1/2 L
131	4	EA	SFL06-32-0.37NY	SCREW FLH SLT 6-32 3/8 L NYL
132	1	EA	42090597-03	WINDOW
134	1	EA	13090803-01	TUBE FTG GAS
135	1	EA	R61002GCB	TERM 16 14 AWG #6
136	0	-	-	-----
138	2	EA	13090623-02	TENSIONER SIDE
139	0	-	-	-----
140	0	-	-	-----
144	1	EA	42060005 04	BOOT MALE GAS
145	2	EA	42060004 01	BOOT MALE POWER/GROUND
146	2	EA	42060000 07	FTG COUPLING HOSE/CABLE

To be used for reference only
PRICE, PART NUMBER AND DESCRIPTION SUBJECT TO CHANGE WITHOUT NOTICE

IPB NUMBER: 090117

TO ORDER
USE PART NUMBER
DO NOT USE IPB
ITEM NUMBER

ARC MACHINES, INC.

PRODUCT MODEL: 9-3500
DESCRIPTION: MAIN ASSEMBLY
MANUAL NUMBER: 730023
NOTES:

IPB ITEM NUMBER	QTY	U/M	PART NUMBER	DESCRIPTION
147	0	-	-	-----
148	0	-	-	-----
171	1	EA	42090749-01	CONDUCTOR GND STRAP
172	1	EA	SPL25-20-0.50NY	SCREW PNH SLT 1/4-20 1/2 L NYL
173	0	-	-	-----
174	1	EA	261-PG-04	FTG NUT/SLEEVE SPRING 1/4 TUBE
175	1	EA	AS200718	SPRING GUARD .34 OD 18.00 LG
176	1	EA	42090548-05	CAM SWITCH
177	2	EA	SCS04-40-0.31NP	SCREW CAP SKT 4-40 5/16 L
178	0	-	-	-----
180	2	EA	13090565-01	LATCH ASSY M9-1500, 2500, 3500
186	1	EA	13090772-01	CONDUCTOR RING 9-3500
187	1	EA	1350110-04	DUST CAP ASSY W/CHAIN (MALE 1/8")
188	1	EA	3057L-1-202	POT TRIM 2K OHM 5%
189	1	EA	130905214-03	CLOSURE FLIP-TOP 9-3500
190	1	EA	420907213-01	PLATE BACKING M9-3500
200	9	FT	DUCT 0.87 50 W	CONDUIT WHT 0.87 ID
201	6	IN	M23053/5-111-0	TBC SHRINK 1 1/2 ID BLK
202	4	EA	13090124-02	SCREW INSULATED

To be used for reference only
PRICE, PART NUMBER AND
DESCRIPTION SUBJECT TO
CHANGE WITHOUT NOTICE

Page 8 of 8

Property of Arc Machines, Inc.

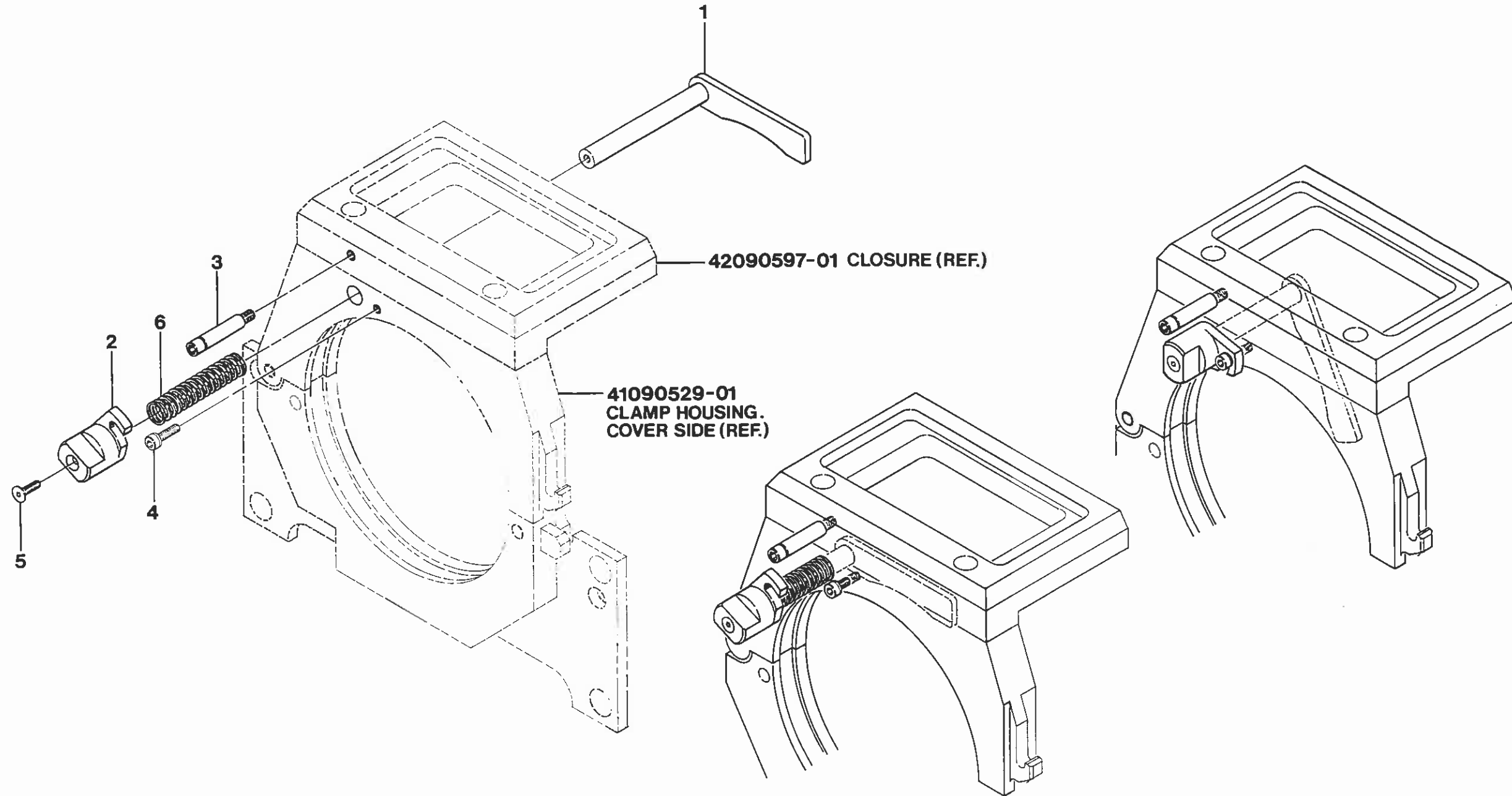

To be used for reference only

Property of Arc Machines, Inc.

MODEL 9-3500
IPB 090515
ARM LOCATING KIT

IPB NUMBER: 090515

TO ORDER
USE PART NUMBER
DO NOT USE IPB
ITEM NUMBER

ARC MACHINES, INC.

PRODUCT MODEL: 9-3500
DESCRIPTION: LOCATING ARM KIT
MANUAL NUMBER: 730023
NOTES:

IPB ITEM NUMBER	QTY	U/M	PART NUMBER	DESCRIPTION
1	1	EA	130905123-02	ARM LOCATING BRAZED
2	1	EA	130905108-01	KNOB ASSY 1500 2500 3500 4500
3	1	EA	420905277-04	STOP (44D22)
4	1	EA	SCS04-40-0.37NP	SCREW CAP SKT 4-40 3/8 L
5	1	EA	SFS02-56-0.31NP	SCREW FLH SKT 2-56 5/16 L
6	1	EA	S-910	SPRING CPRSN .31D 2.00L .024W

To be used for reference only

PRICE, PART NUMBER AND
DESCRIPTION SUBJECT TO
CHANGE WITHOUT NOTICE

Page 2 of 2

Property of Arc Machines, Inc.

THIS DOCUMENT OR DRAWING AND THE INFORMATION CONTAINED HEREIN IS THE PROPERTY OF ARC MACHINES, INC. IS PROPRIETARY, IS SUBMITTED AND RECEIVED IN CONFIDENCE, SHALL BE USED ONLY FOR THE PURPOSE FOR WHICH IT IS SUBMITTED AND SHALL NOT BE COPIED IN WHOLE OR IN PART WITHOUT THE PRIOR EXPRESS WRITTEN PERMISSION OF ARC MACHINES, INC.

ART No.

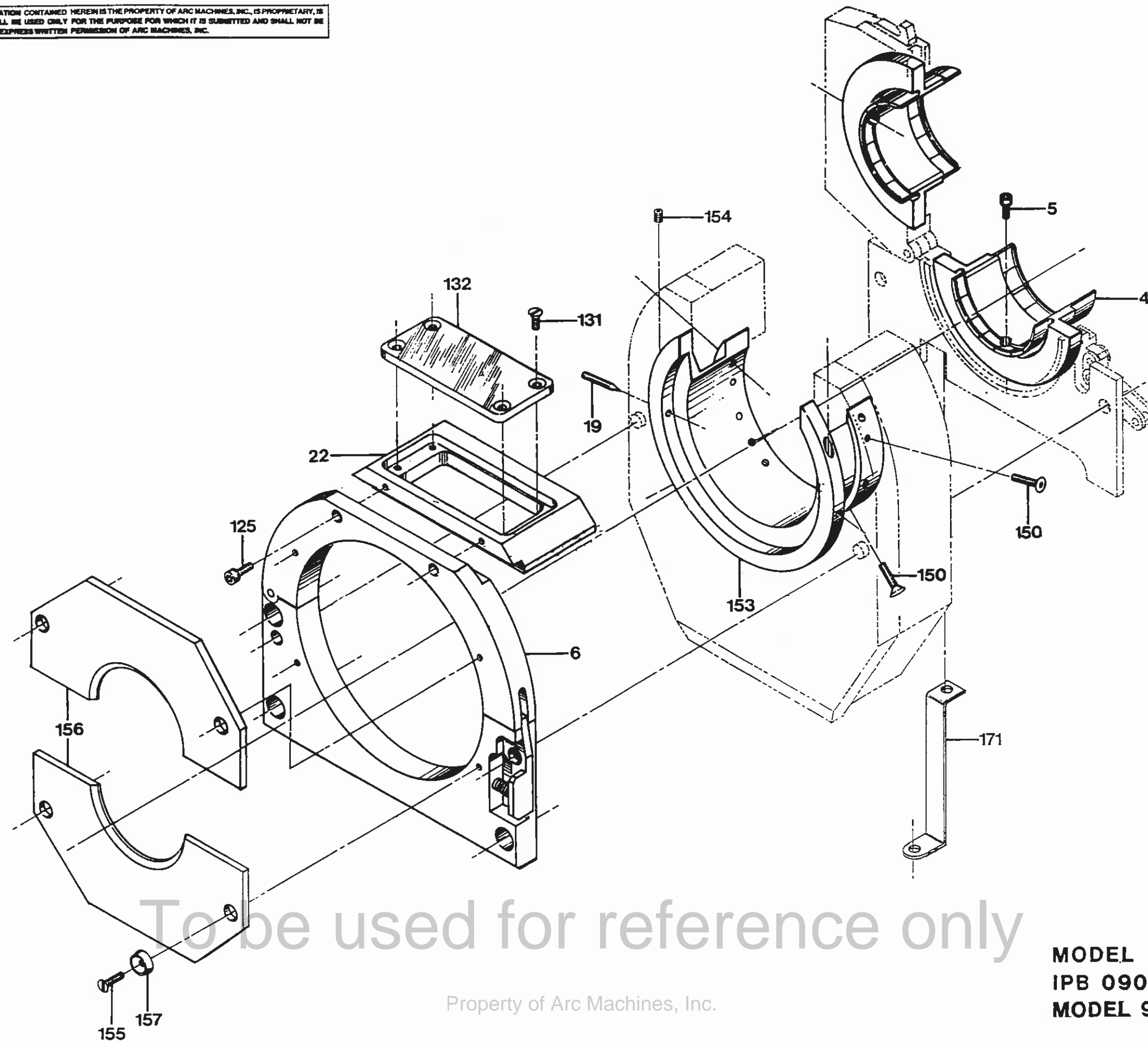

To be used for reference only

Property of Arc Machines, Inc.

MODEL 9E-3500
IPB 090104
MODEL 9E CONFIGURATION

IPB NUMBER: 090104

TO ORDER
USE PART NUMBER
DO NOT USE IPB
ITEM NUMBER

ARC MACHINES, INC.

PRODUCT MODEL: 9-3500
DESCRIPTION: MODEL 9E CONFIGURATION
MANUAL NUMBER: 730023
NOTES:

IPB ITEM NUMBER	QTY	U/M	PART NUMBER	DESCRIPTION	
1	0	-	-	-----	
4	0	-	-	-----	CLAMP INSERTS-ORD BY SIZE
5	2	EA	SCS06-32-0.37NP	SCREW CAP SKT 6-32 3/8 L	
6	1	EA	13090547-01	HOUSING GAS SEAL 9E-3500	
7	0	-	-	-----	
19	0	-	-	-----	TUNGSTEN
22	1	EA	420905185-01	CLOSURE 9E-3500	ITEMS 131 AND 132 INCLUDED
23	0	-	-	-----	
125	2	EA	SCS08-32-0.62NP	SCREW CAP SKT 8-32 5/8 L	
126	0	-	-	-----	
131	4	EA	SFL06-32-0.31NY	SCREW FLH SLT 6-32 5/16 L NYL	
132	1	EA	420905185-02	WINDOW 9E-3500	
133	0	-	-	-----	
150	4	EA	SFS08-32-0.75NP	SCREW FLH SKT 8-32 3/4 L	
151	1	EA	-	-----	
153	1	EA	13090740-01	ROTOR EXTENSION 9E-3500	
154	2	EA	420907144-12	SCREW SET SKT 6-32 3/8 L FLPT	
155	4	EA	SFL08-32-0.50NY	SCREW FLH SLT 8-32 1/2 L NYL	
156	0	-	-	-----	GAS SEALS-ORD BY SIZE
157	4	EA	11SFW0008	WASHER NYLON FINISHING #8	
171	1	EA	42090749-04	GROUND STRAP	
172	0	-	-	-----	
180	1	EA	13090158-03	KIT CVRSN M9-3500 TO M9E-3500	

To be used for reference only

PRICE, PART NUMBER AND
DESCRIPTION SUBJECT TO
CHANGE WITHOUT NOTICE

Page 2 of 2

Property of Arc Machines, Inc.

MODEL 9 CONVERSION TO MODEL 9E INSTRUCTIONS

P/N 750031

(MODELS 9-1500, 9-2500, 9-3500, 9-4500 AND 9-7500)

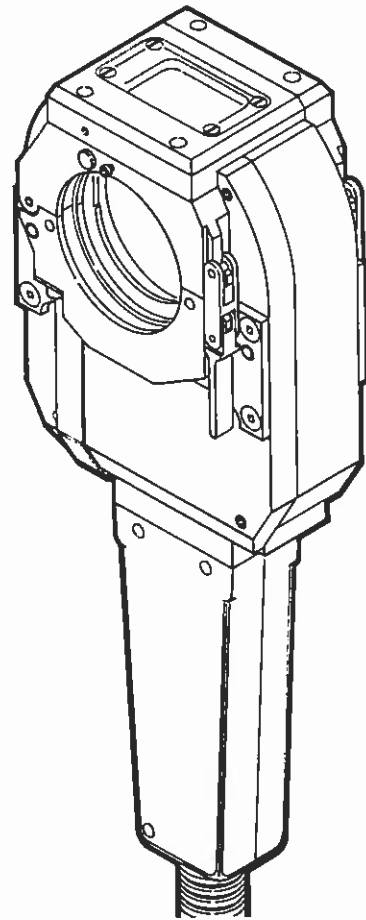

MODEL 9

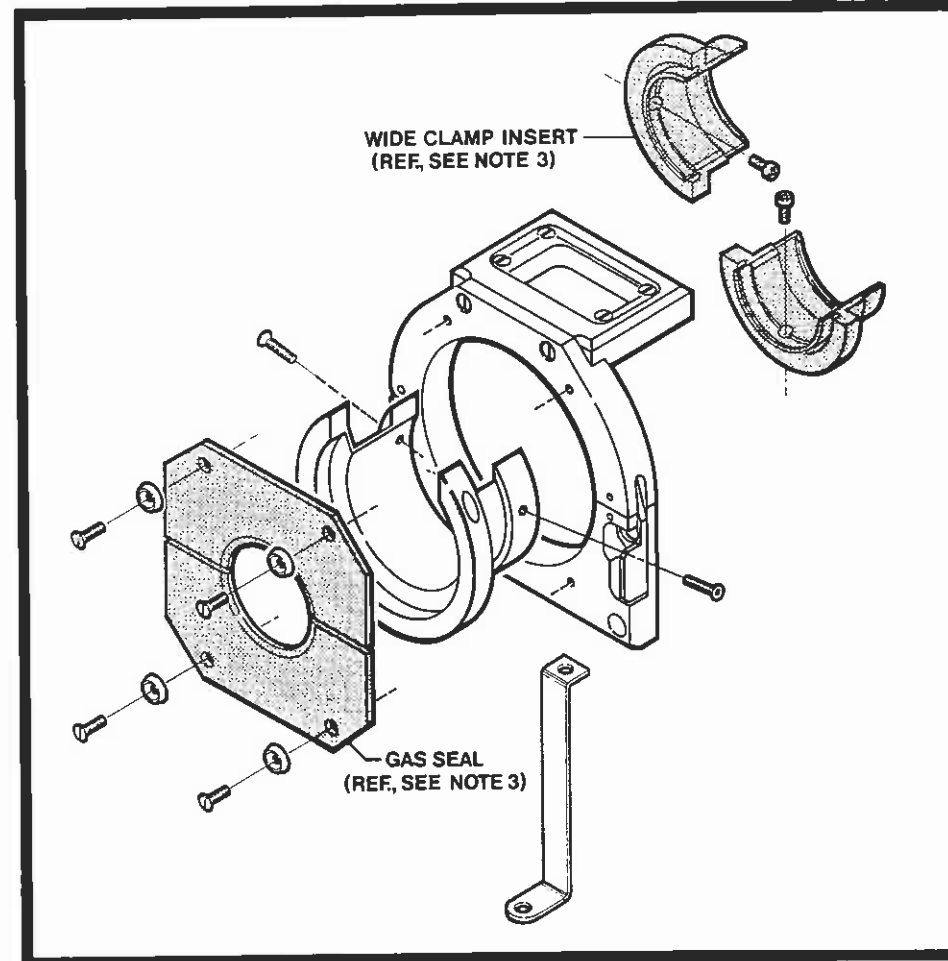

MODEL 9E KIT
(OPTION)

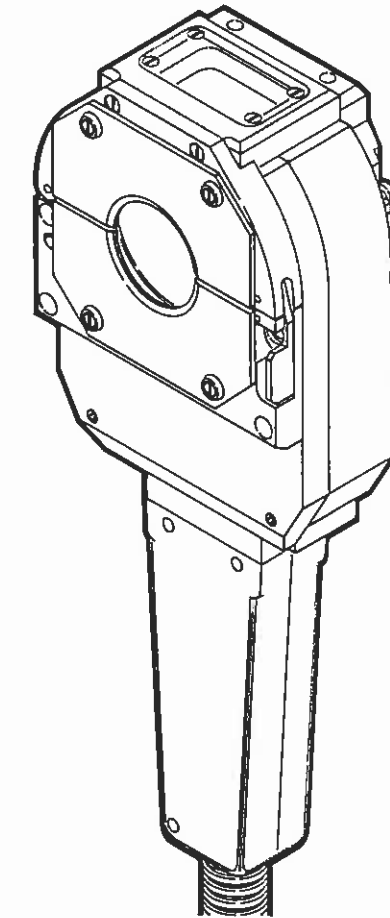

MODEL 9E

NOTES : 1. TO ORDER MODEL 9E KIT SPECIFY WELD HEAD MODEL NUMBER.

2. MODEL 9-2500 USED FOR ILLUSTRATION.

3. WIDE CLAMP INSERT AND GAS SEAL ARE NOT INCLUDED IN KIT.

TO ORDER WIDE CLAMP INSERT AND GAS SEAL SPECIFY TUBE SIZE (O.D.).

To be used for reference only

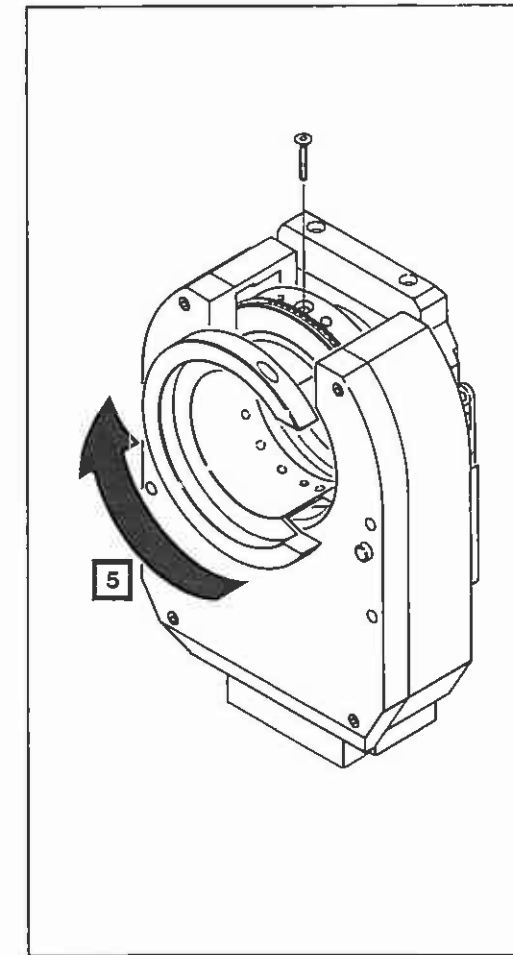
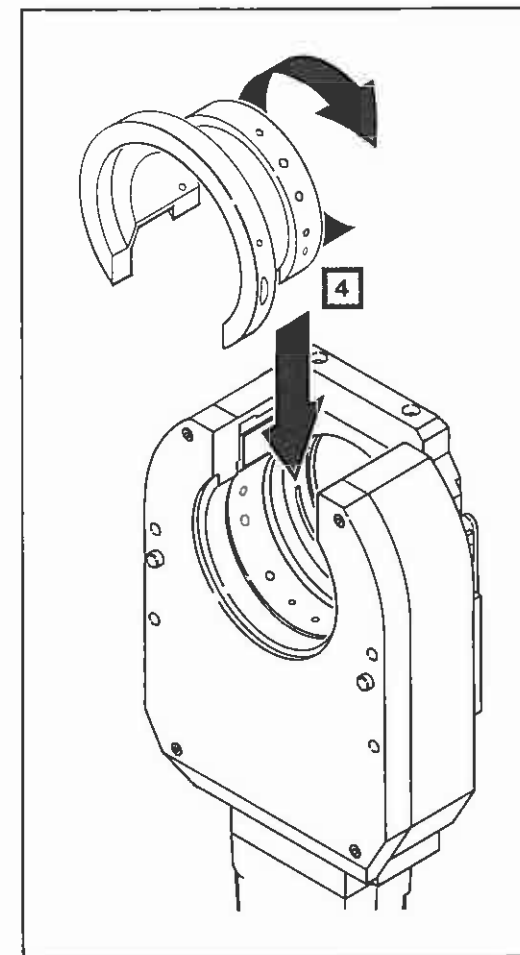
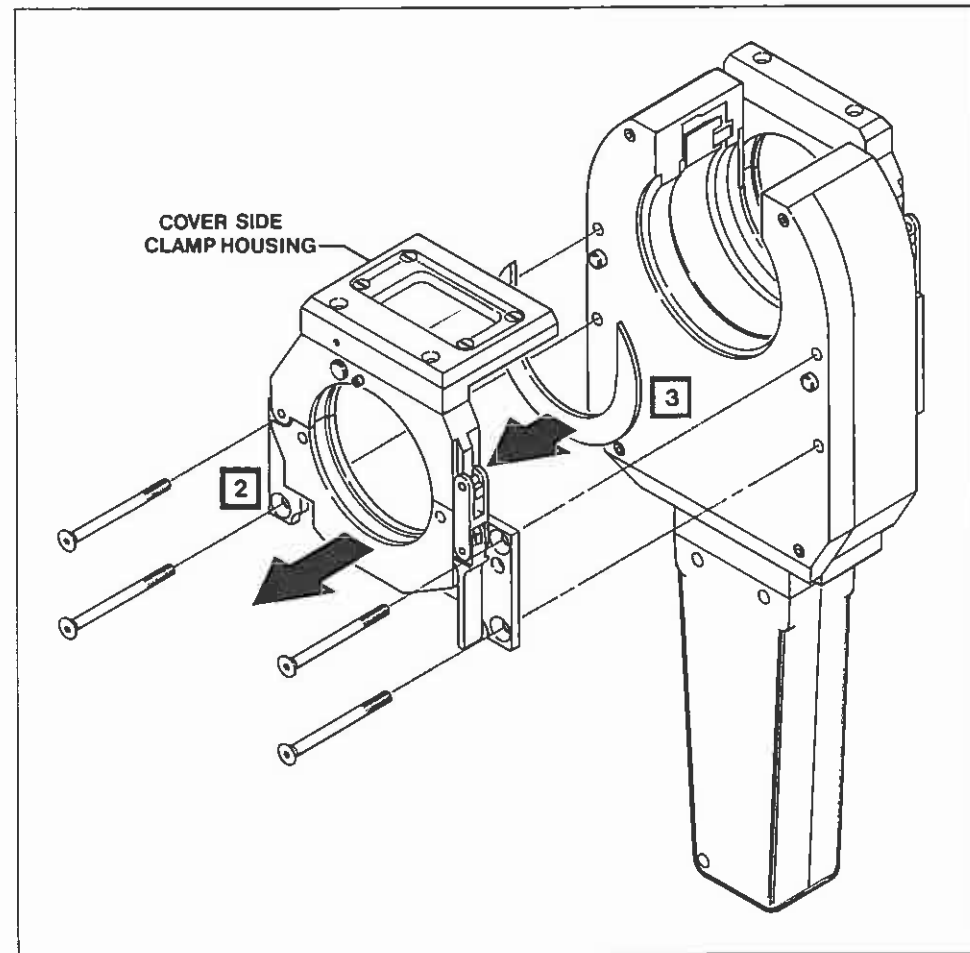
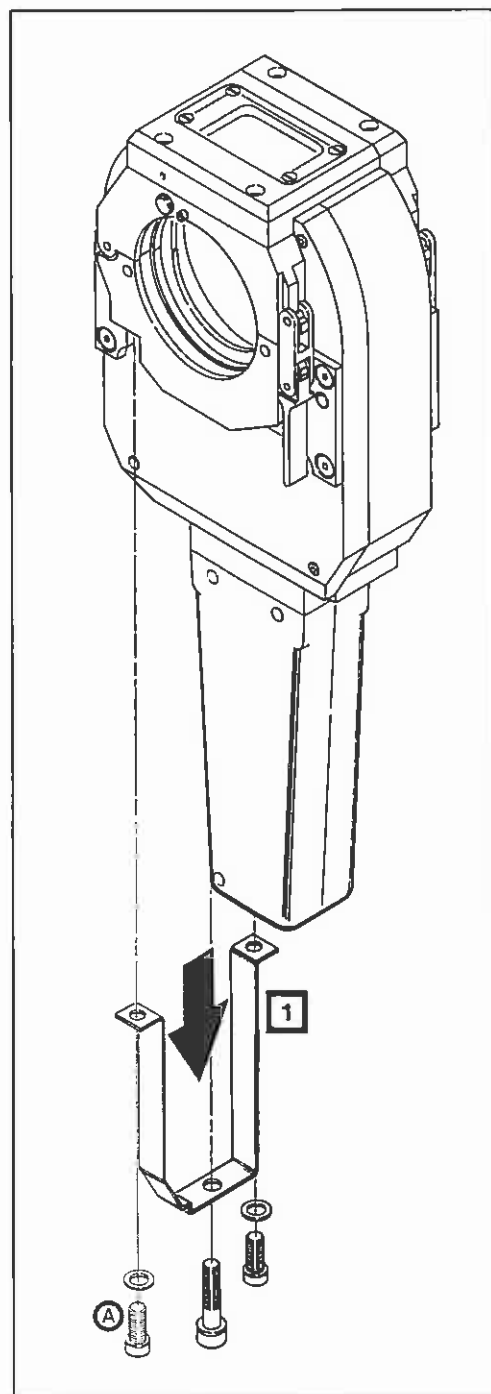

- 1** REMOVE ORIGINAL GROUND STRAP EXCEPT ON MODEL 9-1500 REMOVE SCREW **A** ONLY (ORIGINAL GROUND STRAP IS USED).
- 2** REMOVE COVER SIDE CLAMP HOUSING.
- 3** REMOVE HEAT SHIELD.
- 4** INSTALL ROTOR EXTENSION FROM THE KIT.
- 5** CONNECT WELD HEAD TO POWER SUPPLY AND JOG ROTOR UNTIL ROTOR EXTENSION MOUNTING SCREW HOLE IS ACCESSIBLE. INSTALL MOUNTING SCREWS (2 TO 4 EACH DEPENDING ON MODEL #) AND TIGHTEN.

To be used for reference only

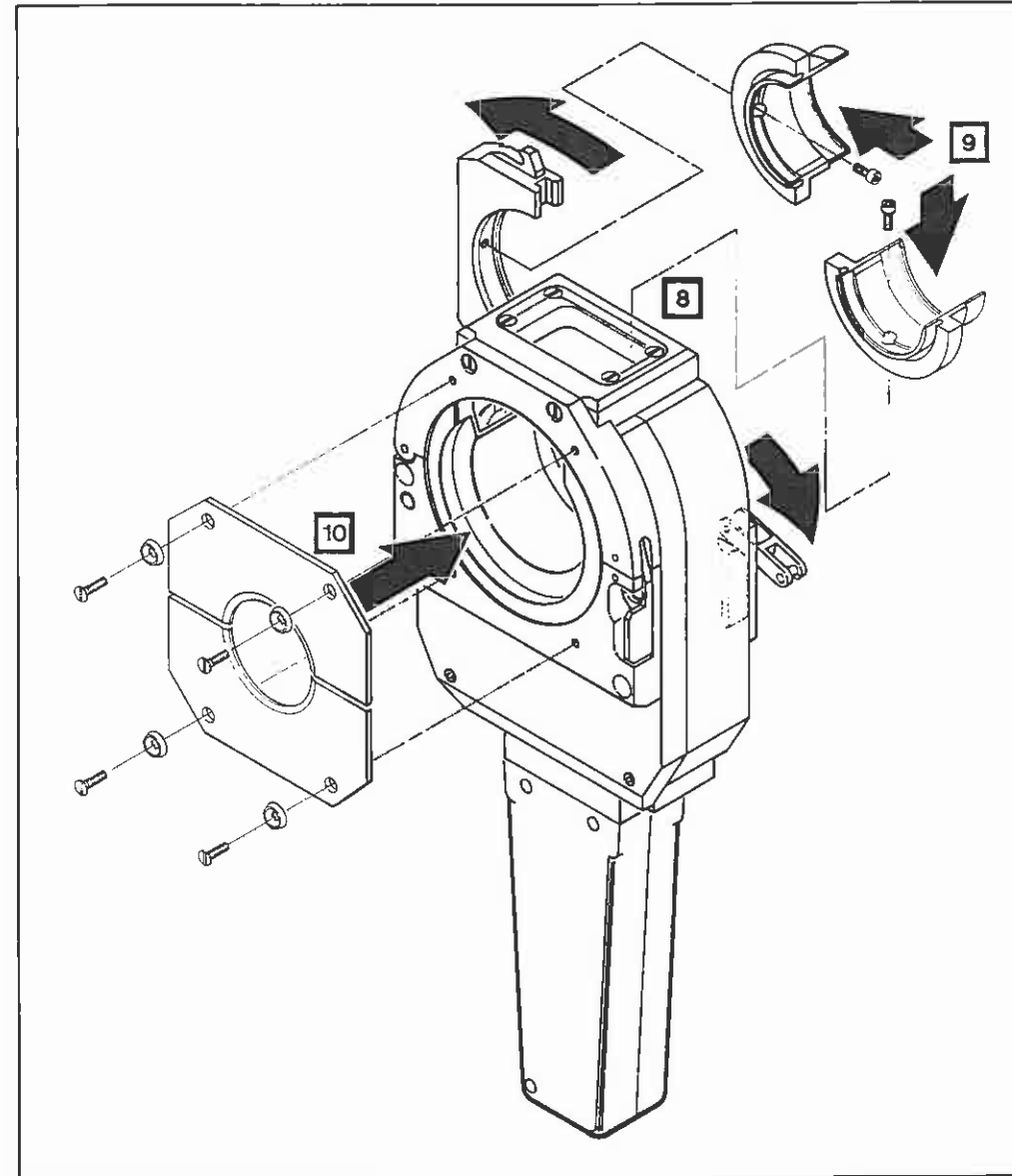
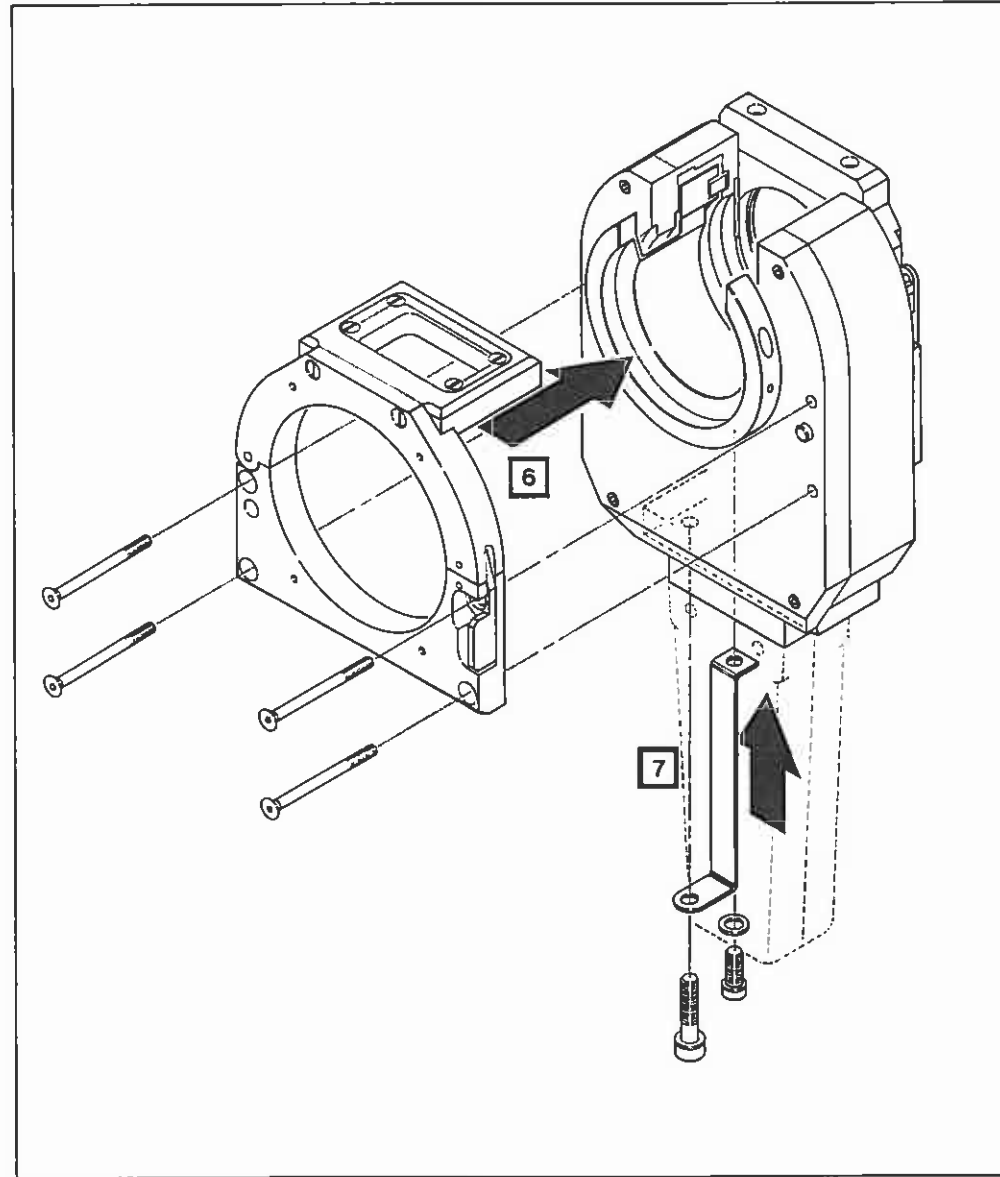

- 6** MOUNT THE GAS SEAL HOUSING ASSEMBLY FROM THE KIT TO THE WELD HEAD USING ORIGINAL SCREWS.
- 7** INSTALL GROUND STRAP FROM THE KIT USING ORIGINAL SCREWS, EXCEPT FOR MODEL 9-1500 USE ORIGINAL GROUND STRAP AND SCREWS.
- 8** OPEN HOUSING SIDE CLAMP.
- 9** INSTALL WIDE CLAMP INSERT ASSEMBLY (NOT PROVIDED IN CONVERSION KIT).
- 10** INSTALL GAS SEAL ASSEMBLY (NOT PROVIDED IN CONVERSION KIT).

To be used for reference only

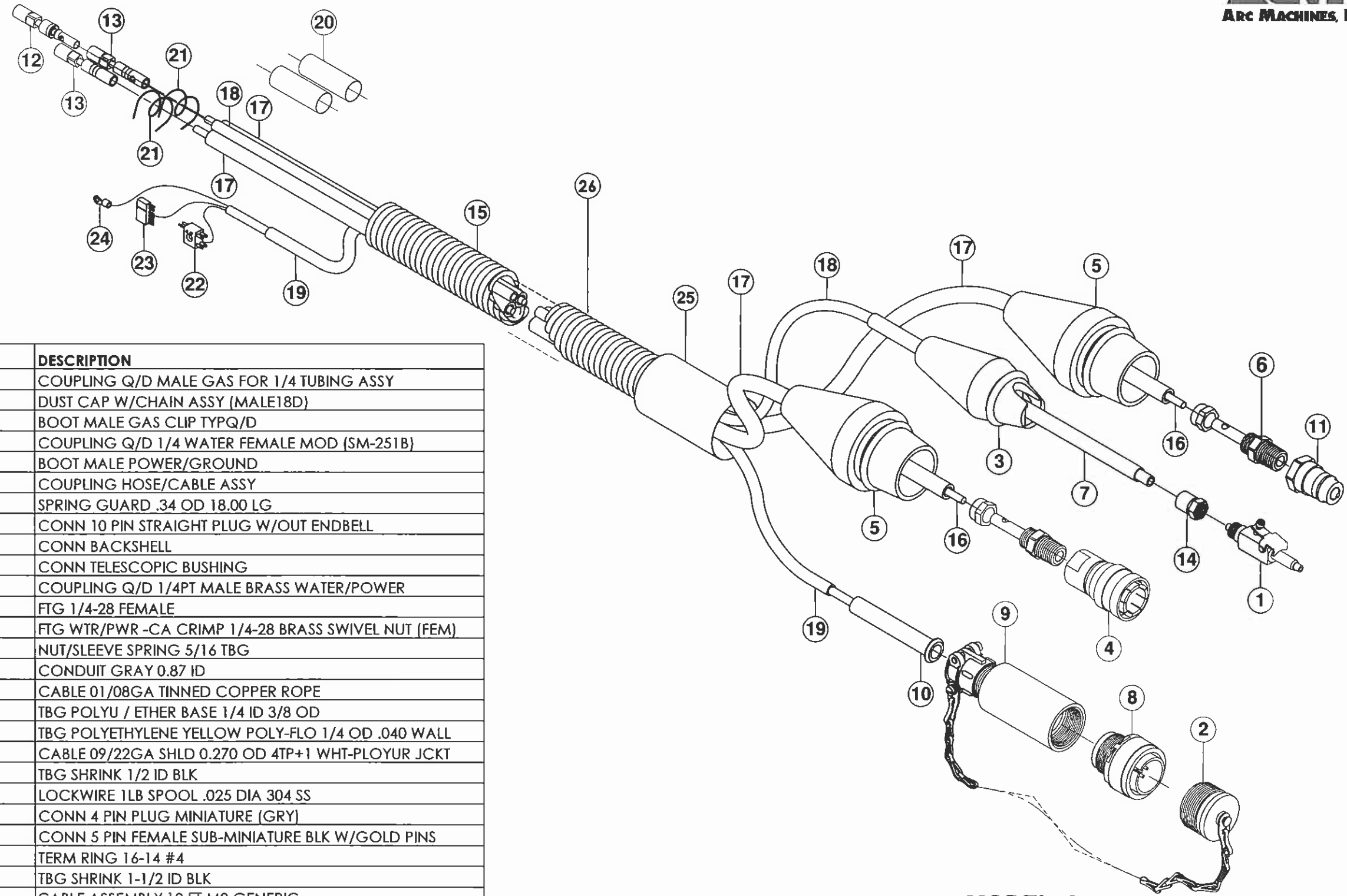

ITEM NO.	QTY.	PART NO.	DESCRIPTION
1	1	1351109-01	COUPLING Q/D MALE GAS FOR 1/4 TUBING ASSY
2	1	1350110-04	DUST CAP W/CHAIN ASSY (MALE18D)
3	1	42060805-04	BOOT MALE GAS CLIP TYPQ/D
4	1	42060800-02	COUPLING Q/D 1/4 WATER FEMALE MOD (SM-251B)
5	2	42060804-01	BOOT MALE POWER/GROUND
6	2	42060800-07	COUPLING HOSE/CABLE ASSY
7	1	AS200718	SPRING GUARD .34 OD 18.00 LG
8	1	MS3106E18-1PF42	CONN 10 PIN STRAIGHT PLUG W/OUT ENDBELL
9	1	G1501N186A3A	CONN BACKSHELL
10	1	MS39056-3	CONN TELESCOPIC BUSHING
11	1	SM-252B	COUPLING Q/D 1/4PT MALE BRASS WATER/POWER
12	1	2PF1	FTG 1/4-28 FEMALE
13	2	ARC-1881	FTG WTR/PWR -CA CRIMP 1/4-28 BRASS SWIVEL NUT (FEM)
14	1	261-PG-04	NUT/SLEEVE SPRING 5/16 TBG
15	1	DUCT-0,87-50-G	CONDUIT GRAY 0.87 ID
16	2	NER7-95-36T	CABLE 01/08GA TINNED COPPER ROPE
17	2	42090806-01	TBG POLYU / ETHER BASE 1/4 ID 3/8 OD
18	1	44-P-YELLOW	TBG POLYETHYLENE YELLOW POLY-FLO 1/4 OD .040 WALL
19	1	CWT11943	CABLE 09/22GA SHLD 0.270 OD 4TP+1 WHT-PLOYUR JCKT
20	2	M23053/5-108-0	TBG SHRINK 1/2 ID BLK
21	2	MS20995C25	LOCKWIRE 1LB SPOOL .025 DIA 304 SS
22	1	JF2P2SCD	CONN 4 PIN PLUG MINIATURE (GRY)
23	1	7052	CONN 5 PIN FEMALE SUB-MINIATURE BLK W/GOLD PINS
24	1	34119	TERM RING 16-14 #4
25	1	M23053/5-111-0	TBG SHRINK 1-1/2 ID BLK
26	-	13090800-01	CABLE ASSEMBLY 10 FT M9 GENERIC

To be used for reference only

**MODEL 9
IPB 090800
CABLE ASSEMBLY**

TO ORDER USE PART NUMBER.
PRICE, PART NUMBER AND DESCRIPTION
SUBJECT TO CHANGE WITHOUT NOTICE.

Property of Arc Machines, Inc.
**THIS IPB SUPERSEDES ALL OTHER IPB'S
REFERENCING 13090800-01 CABLE ASSEMBLY**

ISSUED: 3 JAN 2005
REVISED: 5 OCT 2010

LTR	DCO	REVISED	DATE	BY	APPR
A	1716	C & D ON P.10	11-24-92	MH	
B	2447	ADDED P10A & J10A - REMOVED PN'S FOR P10A, J10A, P4	12-4-97	MC	GAC

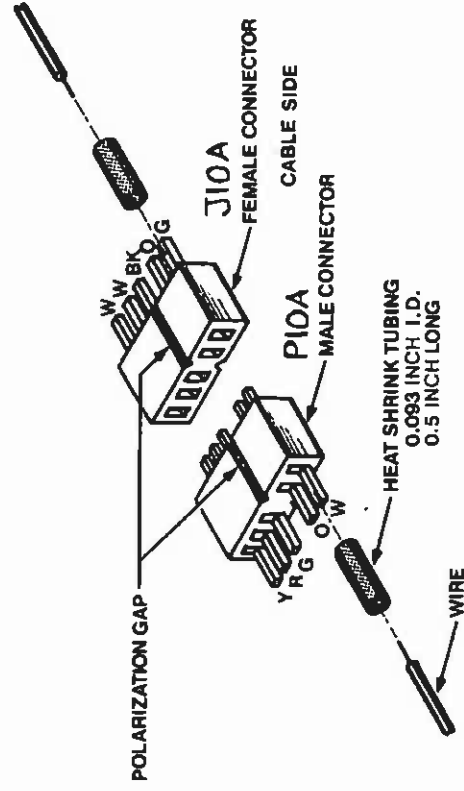
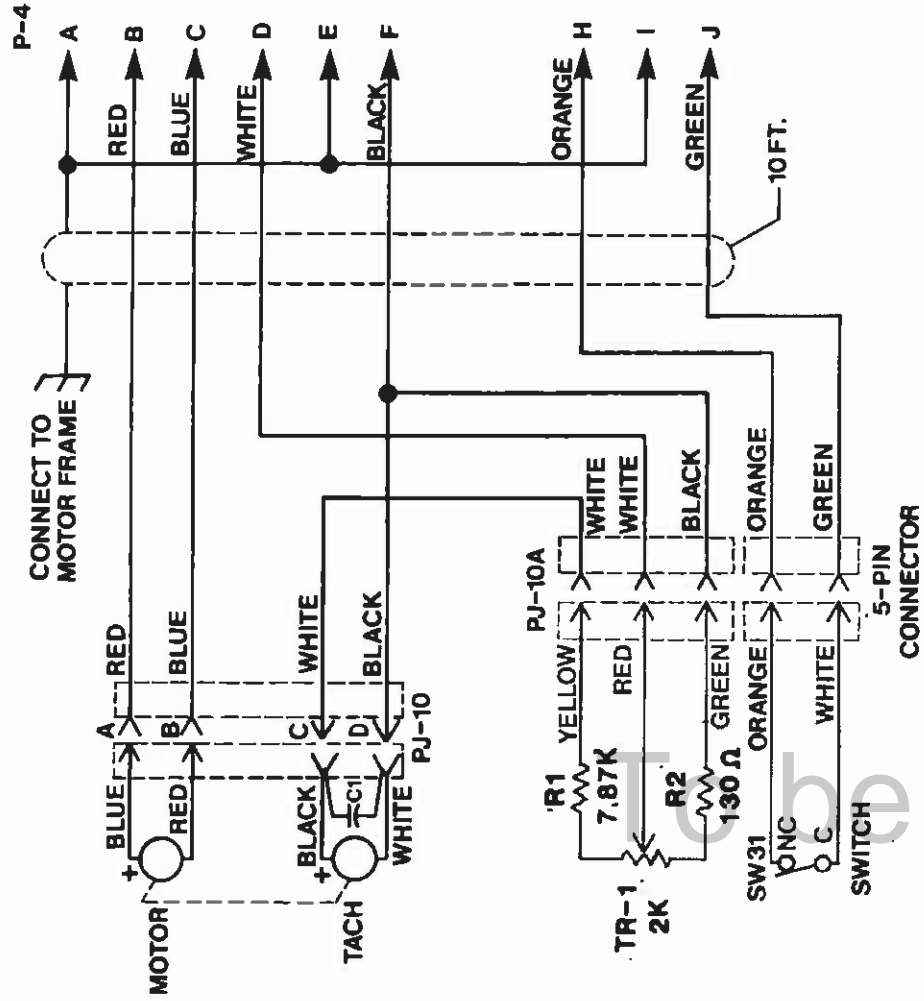

ITEM	QTY	IDENTIFYING NO	NOMENCLATURE OR DESCRIPTION	MFR	PART NO
PARTS LIST					
<small>UNLESS OTHERWISE SPECIFIED ALL DIMENSIONS ARE IN INCHES TOLERANCES ARE FRACTIONS DECIMALS ANGLES X ± .015 XX ± .010 XXX ± .005</small>					
<small>THIS DOCUMENT OR DRAWING AND THE INFORMATION CONTAINED HEREIN IS THE PROPERTY OF ARC MACHINES, INC. IT IS PROPRIETARY. IT IS SUBMITTED AND HEREBY GRANTED THAT IT SHALL BE USED ONLY FOR THE PURPOSE FOR WHICH IT IS SUBMITTED AND SHALL NOT BE COPIED IN WHOLE OR IN PART WITHOUT THE PRIOR EXPRESS WRITTEN PERMISSION OF ARC MACHINES, INC.</small>					
<small>FOR MATERIALIZED STANDARDS SEE DOD-STD-100</small>		<small>THIRD ANGLE PROJECTION</small>			
<small>APPROVALS</small> R. BILEK (MR)		<small>DATE</small> 10-14-85 10-16-85		<small>DESCRIPTION</small> ARC MACHINES INC. MODEL 9 WELD HEAD WIRING DIAGRAM	
<small>ALL MACHINED SURFACES TO BE</small>		<small>SCALE</small> A		<small>MODEL NO. DRWG NO</small> 175144-04	
<small>NEXT ASSY.</small> USED ON		<small>QUOTATION</small>		<small>REV.</small> B	
<small>APPLICATION</small>		<small>DO NOT SCALE DRAWING</small>		<small>SHEET 1 OF 1</small>	

used for reference only